

Rexroth RECO Fieldline PROFIBUS Devices

298518
Edition 01

Project Planning Manual



Title	Rexroth RECO Fieldline PROFIBUS Devices
Type of Documentation	Project Planning Manual
Document Typecode	DOK-CONTRL-RF-FLS-PB**-PR01-EN-P
Internal File Reference	Document Number, 120-0401-B310-01/EN
Purpose of Documentation	This documentation describes the RECO Fieldline PROFIBUS devices.

Record of Revisions

Description	Release Date	Notes
120-0401-B310-01/EN	05/03	First edition

Copyright © 2003 Bosch Rexroth AG
Copying this document, giving it to others and the use or communication of the contents thereof without express authority, are forbidden. Offenders are liable for the payment of damages. All rights are reserved in the event of the grant of a patent or the registration of a utility model or design (DIN 34-1).

Validity The specified data is for product description purposes only and may not be deemed to be guaranteed unless expressly confirmed in the contract. All rights are reserved with respect to the content of this documentation and the availability of the product.

Published by Bosch Rexroth AG
Bgm.-Dr.-Nebel-Str. 2 • D-97816 Lohr a. Main
Telephone +49 (0)93 52/40-0 • Tx 68 94 21 • Fax +49 (0)93 52/40-48 85
<http://www.boschrexroth.com/>
Dept. BRC/EPY (NH)

Note This document has been printed on chlorine-free bleached paper.

Contents

1	System Presentation	1-1
1.1	The Product Family RECO Fieldline	1-1
1.2	Presentation of the Devices	1-1
2	Important Directions for Use	2-1
2.1	Appropriate Use	2-1
	Introduction	2-1
	Areas of Use and Application.....	2-2
2.2	Inappropriate Use.....	2-2
3	Safety Instructions for Electric Drives and Controls	3-1
3.1	Introduction	3-1
3.2	Explanations.....	3-1
3.3	Hazards by Improper Use	3-2
3.4	General Information	3-3
3.5	Protection Against Contact with Electrical Parts.....	3-4
3.6	Protection Against Electric Shock by Protective Low Voltage (PELV)	3-5
3.7	Protection Against Dangerous Movements	3-6
3.8	Protection Against Magnetic and Electromagnetic Fields During Operation and Mounting	3-7
3.9	Protection Against Contact with Hot Parts	3-8
3.10	Protection During Handling and Mounting	3-8
3.11	Battery Safety.....	3-9
3.12	Protection Against Pressurized Systems.....	3-9
4	Stand Alone Device for PROFIBUS DP with 8 Digital Inputs	4-1
4.1	Presentation and Intended Use	4-1
	Features	4-1
	Indicator Elements	4-2
4.2	Technical Data	4-4
	Device Dimensions	4-4
	General Data.....	4-4
	Mechanical Demands	4-4
	Voltage Supply.....	4-5
	Digital Inputs	4-5
	Input Characteristic Curve	4-5
	Sensor Supply.....	4-6
	Error Message to the Higher-Level Control or Computer System.....	4-6
	Interfaces	4-6

	Electrical Isolation/Isolation of the Voltage Areas.....	4-7
4.3	Connections	4-7
	Connections of the Device	4-7
	Pin Assignment	4-8
	PROFIBUS Pin Assignment.....	4-8
	Pin Assignment of the Voltage Supply U_{LS}	4-9
	Pin Assignment of the Inputs	4-9
	Assignment of the Input Sockets	4-10
	Internal Circuit Diagram	4-11
	Connection Example.....	4-12
	Connection Notes	4-12
	Configuration Data	4-13
	Process Data.....	4-13
	Diagnostic Data.....	4-14
5	Stand Alone Device for PROFIBUS DP with 4 Digital Outputs and Inputs	5-1
5.1	Presentation and Intended Use	5-1
	Features	5-1
	Indicator Elements	5-2
5.2	Technical Data	5-4
	Device Dimensions	5-4
	General Data.....	5-4
	Mechanical Demands	5-4
	Voltage Supply.....	5-5
	Digital Inputs	5-5
	Input Characteristic Curve	5-5
	Sensor Supply.....	5-6
	Error Messages to the Higher-Level Control or Computer System	5-6
	Digital Outputs	5-6
	Error Messages.....	5-8
	Output Characteristic Curve When Switched ON (Typical)	5-8
	Output Characteristic Curve When Switched OFF ($U_{AXX} = 30$ V DC; Typical)	5-8
	Output Characteristic Curve for Ground Connection Interrupt ($U_{AXX} = 30$ V DC; Typical).....	5-8
	Interfaces	5-9
	Electrical Isolation/Isolation of the Voltage Areas.....	5-9
5.3	Connections	5-10
	Connections of the Device	5-10
	Pin Assignment	5-10
	PROFIBUS Pin Assignment.....	5-11
	Pin Assignment of the Voltage Supply U_{LS}	5-11
	Pin Assignment of the Voltage Supply U_A of the Outputs.....	5-12
	Pin Assignment of the Inputs and Outputs	5-12
	Assignment of the Input Sockets	5-13
	Internal Circuit Diagram	5-14
	Connection Example.....	5-16
	Connection Notes	5-16

Configuration Data	5-17
Process Data.....	5-17
Diagnostic Data.....	5-18
6 Stand Alone Device for PROFIBUS DP with 8 Digital Outputs	6-1
6.1 Presentation and Intended Use	6-1
Features	6-1
Indicator Elements	6-2
6.2 Technical Data	6-4
Device Dimensions	6-4
General Data.....	6-4
Mechanical Demands	6-4
Voltage Supply.....	6-5
Digital Outputs	6-5
Error Messages.....	6-6
Output Characteristic Curve When Switched ON (Typical)	6-7
Output Characteristic Curve When Switched OFF ($U_{\text{AXX}} = 30 \text{ V DC}$; Typical)	6-7
Output Characteristic Curve for Ground Connection Interrupt ($U_{\text{AXX}} = 30 \text{ V DC}$; Typical).....	6-7
Interfaces	6-8
Electrical Isolation/Isolation of the Voltage Areas.....	6-8
6.3 Connections	6-9
Connections of the Device.....	6-9
Pin Assignment	6-9
PROFIBUS Pin Assignment.....	6-10
Pin Assignment of the Voltage Supply U_{LS}	6-10
Pin Assignment of the Voltage Supply U_{A} of the Outputs.....	6-11
Pin Assignment of the Outputs	6-11
Internal Circuit Diagram	6-12
Connection Example.....	6-14
Connection Notes	6-14
Configuration Data	6-15
Process Data.....	6-15
Diagnostic Data.....	6-16
7 Ordering Information	7-1
7.1 RECO Fieldline PROFIBUS Devices	7-1
7.2 RECO Fieldline PROFIBUS Bus Cables	7-1
7.3 RECO Fieldline Voltage Cables.....	7-1
7.4 RECO Fieldline PROFIBUS Accessories	7-1
7.5 Further Documentation	7-2
8 List of Figures	8-1
9 Service & Support	9-1
9.1 Helpdesk	9-1

9.2 Service-Hotline 9-1

9.3 Internet 9-1

9.4 Vor der Kontaktaufnahme... - Before contacting us..... 9-1

9.5 Kundenbetreuungsstellen - Sales & Service Facilities 9-2

1 System Presentation

1.1 The Product Family RECO Fieldline

The input and output devices of the product family RECO Fieldline are designed for distributed automation tasks in harsh environmental conditions. The devices meet the requirements for IP 65 / IP 67 protection. They enable the direct connection of sensors and actuators in the environment close to the station. This project planning manual describes the devices of the PROFIBUS DP system.



1.2 Presentation of the Devices

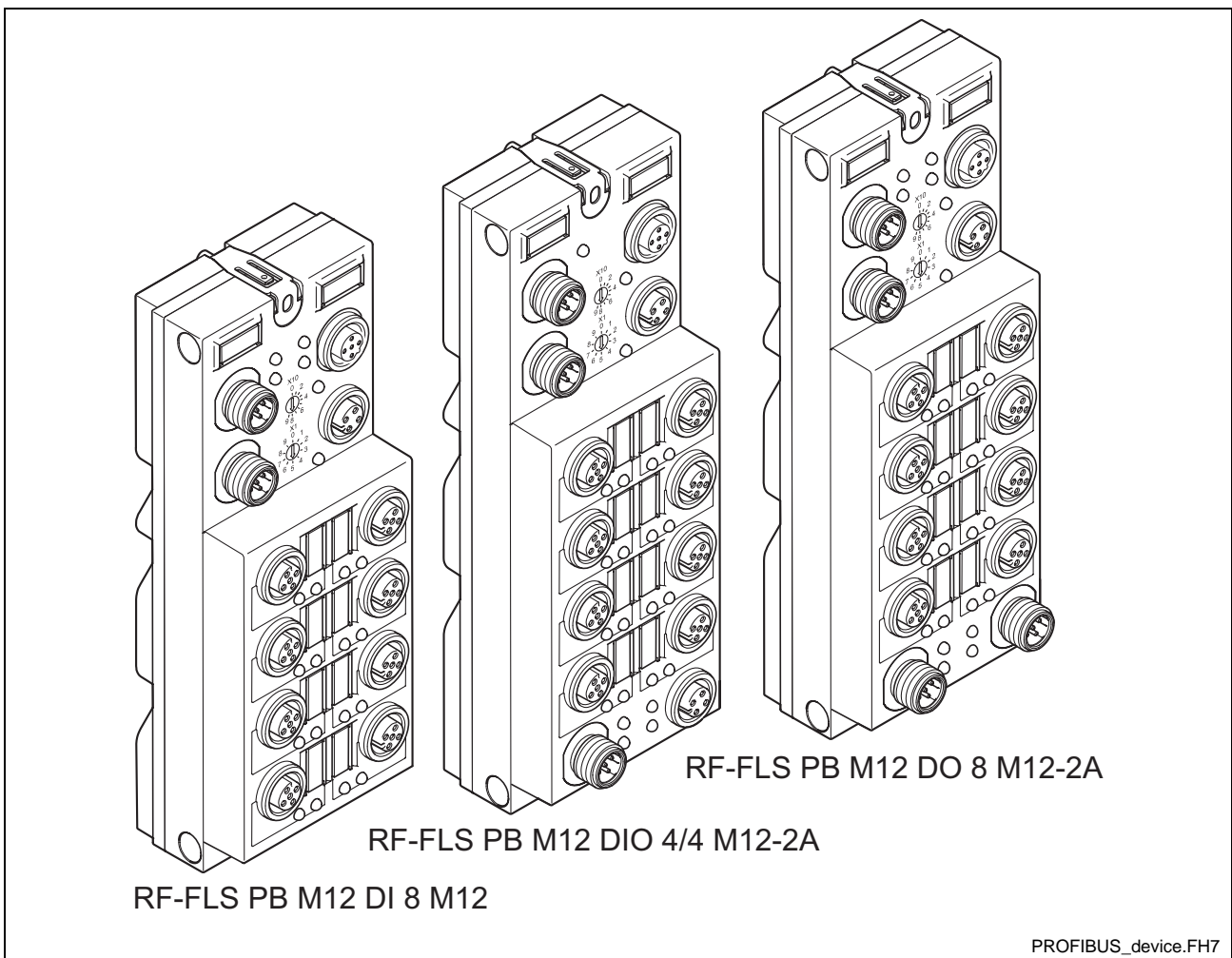

Fig. 1-1: PROFIBUS devices

The following three devices are described in this project planning manual:

- Stand alone device for PROFIBUS DP with 8 digital inputs
RF-FLS PB M12 DI 8 M12
This device is used for digital signal acquisition.
- Stand alone device for PROFIBUS DP with 4 digital outputs and 4 digital inputs
RF-FLS PB M12 DIO 4/4 M12-2A
This device is used for digital signal acquisition and output.
- Stand alone device for PROFIBUS DP with 8 digital outputs
RF-FLS PB M12 DO 8 M12-2A
This device is used for digital signal output.

Note: This project planning manual is only valid in conjunction with the application description DOK-CONTRL-RF-FLS-PB**-AW...-EN-P.

2 Important Directions for Use

2.1 Appropriate Use

Introduction

Bosch Rexroth products represent state-of-the-art developments and manufacturing. They are tested prior to delivery to ensure operating safety and reliability.

The products may only be used in the manner that is defined as appropriate. If they are used in an inappropriate manner, then situations can develop that may lead to property damage or injury to personnel.

Note: Bosch Rexroth, as manufacturer, is not liable for any damages resulting from inappropriate use. In such cases, the guarantee and the right to payment of damages resulting from inappropriate use are forfeited. The user alone carries all responsibility of the risks.

Before using Bosch Rexroth products, make sure that all the prerequisites for appropriate use of the products are satisfied:

- Personnel that in any way, shape or form uses our products must first read and understand the relevant safety instructions and be familiar with appropriate use.
- If the product takes the form of hardware, then they must remain in their original state, in other words, no structural changes are permitted. It is not permitted to decompile software products or alter source codes.
- Do not mount damaged or faulty products or use them in operation.
- Make sure that the products have been installed in the manner described in the relevant documentation.

Areas of Use and Application

The RECO Fieldline system is a distributed modular fieldbus-coupled input and output system. The RECO Fieldline system of Bosch Rexroth is designed for the use in the following application cases:

- Machine tools
- Transfer systems
- General automation

Note: The RECO Fieldline system may only be used with the accessories and parts specified in this document. If a component has not been specifically named, then it may not be either mounted or connected. The same applies to cables and lines.

Operation is only permitted in the specified configurations and combinations of components using the software and firmware as specified in the relevant function descriptions.

Typical areas of application of a RECO Fieldline device are:

- Lathes
- Milling machines
- Machining centers

The RECO Fieldline system may only be operated under the assembly, installation and ambient conditions as described here (temperature, system of protection, humidity, EMC requirements, etc.) and in the position specified.

2.2 Inappropriate Use

Using the RECO Fieldline system outside of the above-referenced areas of application or under operating conditions other than described in the document and the technical data specified is defined as "inappropriate use".

The RECO Fieldline system may not be used, if

- it is subject to operating conditions that do not meet the above specified ambient conditions. This includes, for example, operation under water, in the case of extreme temperature fluctuations or extreme maximum temperatures

or if

- Bosch Rexroth has not specifically released them for that intended purpose. Please note the specifications outlined in the general Safety Instructions!

3 Safety Instructions for Electric Drives and Controls

3.1 Introduction

Read these instructions before the initial startup of the equipment in order to eliminate the risk of bodily harm or material damage. Follow these safety instructions at all times.

Do not attempt to install or start up this equipment without first reading all documentation provided with the product. Read and understand these safety instructions and all user documentation of the equipment prior to working with the equipment at any time. If you do not have the user documentation for your equipment, contact your local Bosch Rexroth representative to send this documentation immediately to the person or persons responsible for the safe operation of this equipment.

If the equipment is resold, rented or transferred or passed on to others, then these safety instructions must be delivered with the equipment.



Improper use of this equipment, failure to follow the safety instructions in this document or tampering with the product, including disabling of safety devices, may result in material damage, bodily harm, electric shock or even death!

3.2 Explanations

The safety instructions describe the following degrees of hazard seriousness in compliance with ANSI Z535. The degree of hazard seriousness informs about the consequences resulting from non-compliance with the safety instructions.



Warning symbol with signal word	Degree of hazard seriousness according to ANSI
 DANGER	Death or severe bodily harm will occur.
 WARNING	Death or severe bodily harm may occur.
 CAUTION	Bodily harm or material damage may occur.

Fig. 3-1: Hazard classification (according to ANSI Z535)

3.3 Hazards by Improper Use



DANGER

**High voltage and high discharge current!
Danger to life or severe bodily harm by electric shock!**



DANGER

Dangerous movements! Danger to life, severe bodily harm or material damage by unintentional motor movements!



WARNING

High electrical voltage due to wrong connections! Danger to life or bodily harm by electric shock!



WARNING

Health hazard for persons with heart pacemakers, metal implants and hearing aids in proximity to electrical equipment!



CAUTION

Surface of machine housing could be extremely hot! Danger of injury! Danger of burns!



CAUTION

Risk of injury due to improper handling! Bodily harm caused by crushing, shearing, cutting and mechanical shock or incorrect handling of pressurized systems!



CAUTION

Risk of injury due to incorrect handling of batteries!

3.4 General Information

- Bosch Rexroth AG is not liable for damages resulting from failure to observe the warnings provided in this documentation.
- Read the operating, maintenance and safety instructions in your language before starting up the machine. If you find that you cannot completely understand the documentation for your product, please ask your supplier to clarify.
- Proper and correct transport, storage, assembly and installation as well as care in operation and maintenance are prerequisites for optimal and safe operation of this equipment.
- Only persons who are trained and qualified for the use and operation of the equipment may work on this equipment or within its proximity.
 - The persons are qualified if they have sufficient knowledge of the assembly, installation and operation of the equipment as well as an understanding of all warnings and precautionary measures noted in these instructions.
 - Furthermore, they must be trained, instructed and qualified to switch electrical circuits and equipment on and off in accordance with technical safety regulations, to ground them and to mark them according to the requirements of safe work practices. They must have adequate safety equipment and be trained in first aid.
- Only use spare parts and accessories approved by the manufacturer.
- Follow all safety regulations and requirements for the specific application as practiced in the country of use.
- The equipment is designed for installation in industrial machinery.
- The ambient conditions given in the product documentation must be observed.
- Use only safety features and applications that are clearly and explicitly approved in the Project Planning Manual.

For example, the following areas of use are not permitted: construction cranes, elevators used for people or freight, devices and vehicles to transport people, medical applications, refinery plants, transport of hazardous goods, nuclear applications, applications sensitive to high frequency, mining, food processing, control of protection equipment (also in a machine).
- The information given in the documentation of the product with regard to the use of the delivered components contains only examples of applications and suggestions.

The machine and installation manufacturer must

 - make sure that the delivered components are suited for his individual application and check the information given in this documentation with regard to the use of the components,
 - make sure that his application complies with the applicable safety regulations and standards and carry out the required measures, modifications and complements.
- Startup of the delivered components is only permitted once it is sure that the machine or installation in which they are installed complies with the national regulations, safety specifications and standards of the application.
- Technical data, connections and operational conditions are specified in the product documentation and must be followed at all times.

- Operation is only permitted if the national EMC regulations for the application are met.
The instructions for installation in accordance with EMC requirements can be found in the documentation "EMC in Drive and Control Systems".
The machine or installation manufacturer is responsible for compliance with the limiting values as prescribed in the national regulations.

3.5 Protection Against Contact with Electrical Parts

Note: This section refers to equipment and drive components with voltages above 50 Volts.

Touching live parts with voltages of 50 Volts and more with bare hands or conductive tools or touching ungrounded housings can be dangerous and cause electric shock. In order to operate electrical equipment, certain parts must unavoidably have dangerous voltages applied to them.



DANGER

High electrical voltage! Danger to life, severe bodily harm by electric shock!

- ⇒ Only those trained and qualified to work with or on electrical equipment are permitted to operate, maintain or repair this equipment.
 - ⇒ Follow general construction and safety regulations when working on high voltage installations.
 - ⇒ Before switching on power the ground wire must be permanently connected to all electrical units according to the connection diagram.
 - ⇒ Do not operate electrical equipment at any time, even for brief measurements or tests, if the ground wire is not permanently connected to the points of the components provided for this purpose.
 - ⇒ Before working with electrical parts with voltage higher than 50 V, the equipment must be disconnected from the mains voltage or power supply. Make sure the equipment cannot be switched on again unintended.
 - ⇒ The following should be observed with electrical drive and filter components:
 - ⇒ Wait five (5) minutes after switching off power to allow capacitors to discharge before beginning to work. Measure the voltage on the capacitors before beginning to work to make sure that the equipment is safe to touch.
 - ⇒ Never touch the electrical connection points of a component while power is turned on.
 - ⇒ Install the covers and guards provided with the equipment properly before switching the equipment on. Prevent contact with live parts at any time.
 - ⇒ A residual-current-operated protective device (RCD) must not be used on electric drives! Indirect contact must be prevented by other means, for example, by an overcurrent protective device.
 - ⇒ Electrical components with exposed live parts and uncovered high voltage terminals must be installed in a protective housing, for example, in a control cabinet.
-

To be observed with electrical drive and filter components:



DANGER

**High electrical voltage on the housing!
High leakage current! Danger to life, danger of
injury by electric shock!**

- ⇒ Connect the electrical equipment, the housings of all electrical units and motors permanently with the safety conductor at the ground points before power is switched on. Look at the connection diagram. This is even necessary for brief tests.
 - ⇒ Connect the safety conductor of the electrical equipment always permanently and firmly to the supply mains. Leakage current exceeds 3.5 mA in normal operation.
 - ⇒ Use a copper conductor with at least 10 mm² cross section over its entire course for this safety conductor connection!
 - ⇒ Prior to startups, even for brief tests, always connect the protective conductor or connect with ground wire. Otherwise, high voltages can occur on the housing that lead to electric shock.
-

3.6 Protection Against Electric Shock by Protective Low Voltage (PELV)

All connections and terminals with voltages between 0 and 50 Volts on Rexroth products are protective low voltages designed in accordance with international standards on electrical safety.



WARNING

**High electrical voltage due to wrong
connections! Danger to life, bodily harm by
electric shock!**

- ⇒ Only connect equipment, electrical components and cables of the protective low voltage type (PELV = Protective Extra Low Voltage) to all terminals and clamps with voltages of 0 to 50 Volts.
 - ⇒ Only electrical circuits may be connected which are safely isolated against high voltage circuits. Safe isolation is achieved, for example, with an isolating transformer, an opto-electronic coupler or when battery-operated.
-

3.7 Protection Against Dangerous Movements

Dangerous movements can be caused by faulty control of the connected motors. Some common examples are:

- improper or wrong wiring of cable connections
- incorrect operation of the equipment components
- wrong input of parameters before operation
- malfunction of sensors, encoders and monitoring devices
- defective components
- software or firmware errors

Dangerous movements can occur immediately after equipment is switched on or even after an unspecified time of trouble-free operation.

The monitoring in the drive components will normally be sufficient to avoid faulty operation in the connected drives. Regarding personal safety, especially the danger of bodily injury and material damage, this alone cannot be relied upon to ensure complete safety. Until the integrated monitoring functions become effective, it must be assumed in any case that faulty drive movements will occur. The extent of faulty drive movements depends upon the type of control and the state of operation.



Dangerous movements! Danger to life, risk of injury, severe bodily harm or material damage!

- ⇒ Ensure personal safety by means of qualified and tested higher-level monitoring devices or measures integrated in the installation. Unintended machine motion is possible if monitoring devices are disabled, bypassed or not activated.
- ⇒ Pay attention to unintended machine motion or other malfunction in any mode of operation.
- ⇒ Keep free and clear of the machine's range of motion and moving parts. Possible measures to prevent people from accidentally entering the machine's range of motion:
 - use safety fences
 - use safety guards
 - use protective coverings
 - install light curtains or light barriers
- ⇒ Fences and coverings must be strong enough to resist maximum possible momentum, especially if there is a possibility of loose parts flying off.
- ⇒ Mount the emergency stop switch in the immediate reach of the operator. Verify that the emergency stop works before startup. Don't operate the machine if the emergency stop is not working.
- ⇒ Isolate the drive power connection by means of an emergency stop circuit or use a starting lockout to prevent unintentional start.

Make sure that the drives are brought to a safe standstill before accessing or entering the danger zone. Safe standstill can be achieved by switching off the power supply contactor or by safe mechanical locking of moving parts.

- ⇒ Secure vertical axes against falling or dropping after switching off the motor power by, for example:
 - mechanically securing the vertical axes
 - adding an external braking/ arrester/ clamping mechanism
 - ensuring sufficient equilibration of the vertical axes
 The standard equipment motor brake or an external brake controlled directly by the drive controller are not sufficient to guarantee personal safety!
- ⇒ Disconnect electrical power to the equipment using a master switch and secure the switch against reconnection for:
 - maintenance and repair work
 - cleaning of equipment
 - long periods of discontinued equipment use
- ⇒ Prevent the operation of high-frequency, remote control and radio equipment near electronics circuits and supply leads. If the use of such equipment cannot be avoided, verify the system and the installation for possible malfunctions in all possible positions of normal use before initial startup. If necessary, perform a special electromagnetic compatibility (EMC) test on the installation.

3.8 Protection Against Magnetic and Electromagnetic Fields During Operation and Mounting

Magnetic and electromagnetic fields generated near current-carrying conductors and permanent magnets in motors represent a serious health hazard to persons with heart pacemakers, metal implants and hearing aids.



WARNING

Health hazard for persons with heart pacemakers, metal implants and hearing aids in proximity to electrical equipment!

- ⇒ Persons with heart pacemakers, hearing aids and metal implants are not permitted to enter the following areas:
 - Areas in which electrical equipment and parts are mounted, being operated or started up.
 - Areas in which parts of motors with permanent magnets are being stored, operated, repaired or mounted.
- ⇒ If it is necessary for a person with a heart pacemaker to enter such an area, then a doctor must be consulted prior to doing so. Heart pacemakers that are already implanted or will be implanted in the future, have a considerable variation in their electrical noise immunity. Therefore there are no rules with general validity.
- ⇒ Persons with hearing aids, metal implants or metal pieces must consult a doctor before they enter the areas described above. Otherwise, health hazards will occur.

3.9 Protection Against Contact with Hot Parts



CAUTION

**Housing surfaces could be extremely hot!
Danger of injury! Danger of burns!**

- ⇒ Do not touch housing surfaces near sources of heat! Danger of burns!
 - ⇒ After switching the equipment off, wait at least ten (10) minutes to allow it to cool down before touching it.
 - ⇒ Do not touch hot parts of the equipment, such as housings with integrated heat sinks and resistors. Danger of burns!
-

3.10 Protection During Handling and Mounting

Under certain conditions, incorrect handling and mounting of parts and components may cause injuries.



CAUTION

Risk of injury by incorrect handling! Bodily harm caused by crushing, shearing, cutting and mechanical shock!

- ⇒ Observe general installation and safety instructions with regard to handling and mounting.
 - ⇒ Use appropriate mounting and transport equipment.
 - ⇒ Take precautions to avoid pinching and crushing.
 - ⇒ Use only appropriate tools. If specified by the product documentation, special tools must be used.
 - ⇒ Use lifting devices and tools correctly and safely.
 - ⇒ For safe protection wear appropriate protective clothing, e.g. safety glasses, safety shoes and safety gloves.
 - ⇒ Never stand under suspended loads.
 - ⇒ Clean up liquids from the floor immediately to prevent slipping.
-

3.11 Battery Safety

Batteries contain reactive chemicals in a solid housing. Inappropriate handling may result in injuries or material damage.



CAUTION

Risk of injury by incorrect handling!

- ⇒ Do not attempt to reactivate discharged batteries by heating or other methods (danger of explosion and cauterization).
- ⇒ Never charge non-chargeable batteries (danger of leakage and explosion).
- ⇒ Never throw batteries into a fire.
- ⇒ Do not dismantle batteries.
- ⇒ Do not damage electrical components installed in the equipment.

Note: Be aware of environmental protection and disposal! The batteries contained in the product should be considered as hazardous material for land, air and sea transport in the sense of the legal requirements (danger of explosion). Dispose batteries separately from other waste. Observe the legal requirements in the country of installation.

3.12 Protection Against Pressurized Systems

Certain motors and drive controllers, corresponding to the information in the respective Project Planning Manual, must be provided with pressurized media, such as compressed air, hydraulic oil, cooling fluid and cooling lubricant supplied by external systems. Incorrect handling of the supply and connections of pressurized systems can lead to injuries or accidents. In these cases, improper handling of external supply systems, supply lines or connections can cause injuries or material damage.



CAUTION

Danger of injury by incorrect handling of pressurized systems !

- ⇒ Do not attempt to disassemble, to open or to cut a pressurized system (danger of explosion).
- ⇒ Observe the operation instructions of the respective manufacturer.
- ⇒ Before disassembling pressurized systems, release pressure and drain off the fluid or gas.
- ⇒ Use suitable protective clothing (for example safety glasses, safety shoes and safety gloves)
- ⇒ Remove any fluid that has leaked out onto the floor immediately.

Note: Environmental protection and disposal! The media used in the operation of the pressurized system equipment may not be environmentally compatible. Media that are damaging the environment must be disposed separately from normal waste. Observe the legal requirements in the country of installation.

Notes

4 Stand Alone Device for PROFIBUS DP with 8 Digital Inputs

4.1 Presentation and Intended Use

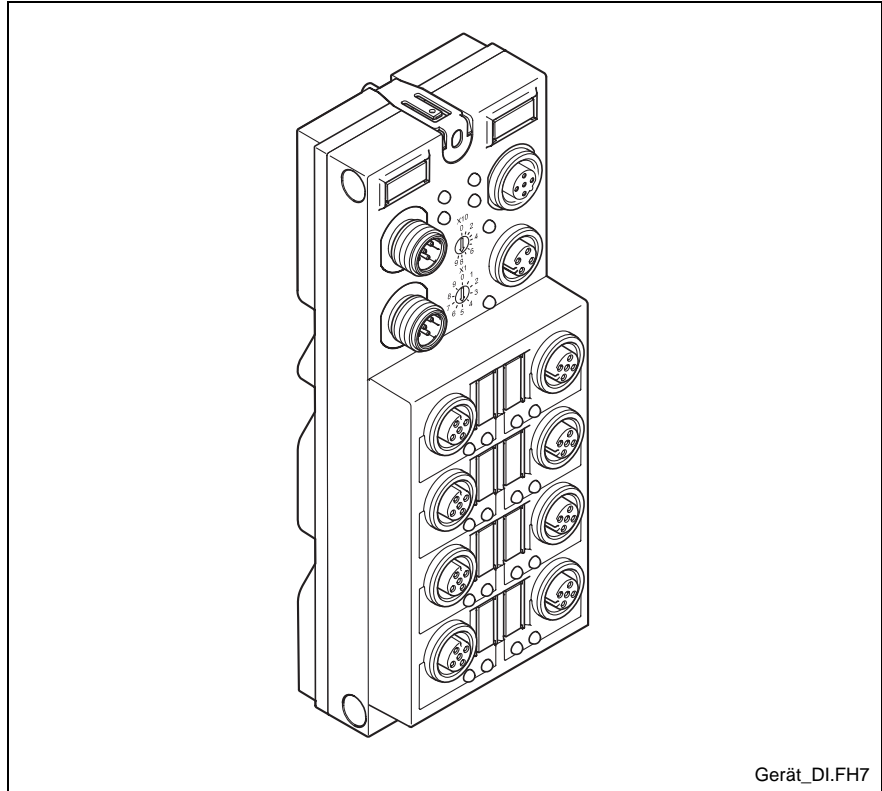

Fig. 4-1: RECO Fieldline device RF-FLS PB M12 DI 8 M12

This device is used for digital signal acquisition.

Features

- Connection to PROFIBUS DP using M12 connectors (B-encoded)
- Baud rate with up to 12 Mbaud autobaud
- Connection of digital sensors using M12 connectors
- Flexible voltage supply concept
- Diagnostic and status indicators
- Short-circuit and overload protection of sensor supply
- IP 65 / IP 67 degrees of protection

Indicator Elements

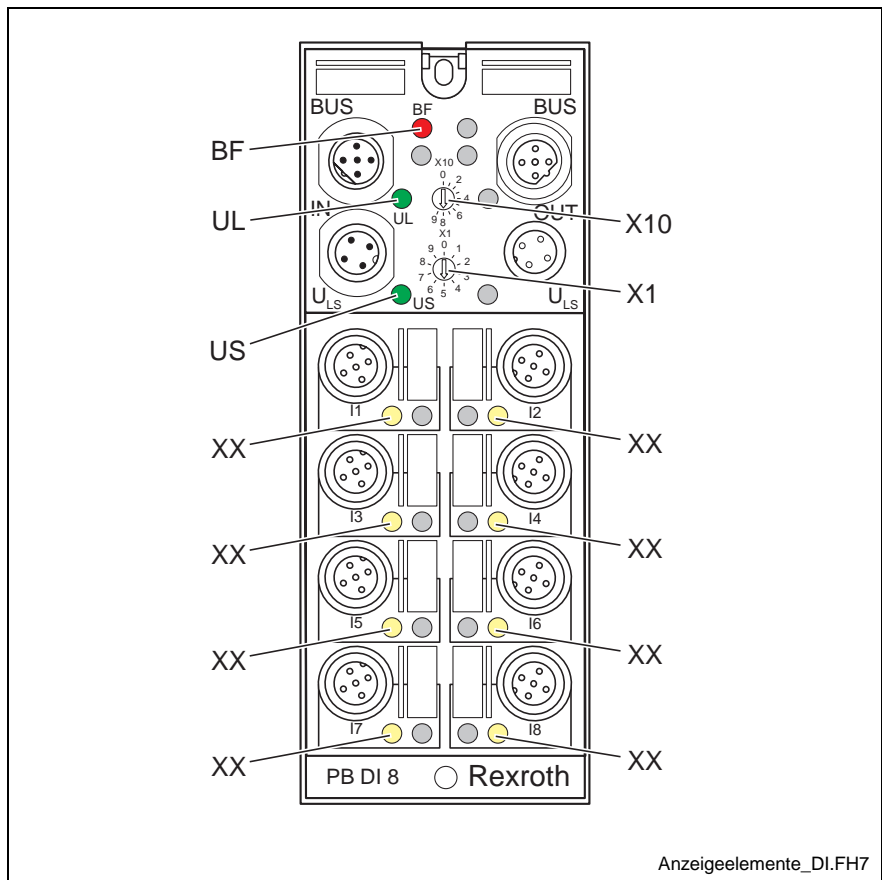

Fig. 4-2: Diagnostic and status indicators

Rotary Encoding Switches

The station address is set using the rotary encoding switches X10 (for the first digit of a two-digit number) and X1 (for the second digit of a two-digit number). The PROFIBUS master addresses the device by means of this station address.

Note: The valid value range is between 1 and 99.
A new address value is only accepted upon device power-up.

Des.	Color	Meaning
BF	Red LED:	Bus failure
	ON:	No cyclic data transmission: <ul style="list-style-type: none"> • PROFIBUS not connected, master not active • Incorrect settings (configuration via master, station address) • Synchronization or parameterization running • Timeout expired
	OFF:	<ul style="list-style-type: none"> • Device is addressed by PROFIBUS and is in the "cyclic process data exchange" state • Missing device supply (In this state the "UL" LED is also off because of the missing 24 V communications voltage.)
UL	Green LED:	Communications power
	ON:	Communications power present
	OFF:	Communications power too low
US	Red/green LED:	Voltage supply for inputs IN1 to IN8
	ON (red):	Voltage supply overloaded
	ON (green):	Voltage supply present
	OFF:	Voltage supply too low
XX	Yellow LED:	Status indicators of the inputs
	ON:	Input active
	OFF:	Input not active

Fig. 4-3: Local diagnostic and status indicators

4.2 Technical Data

Device Dimensions

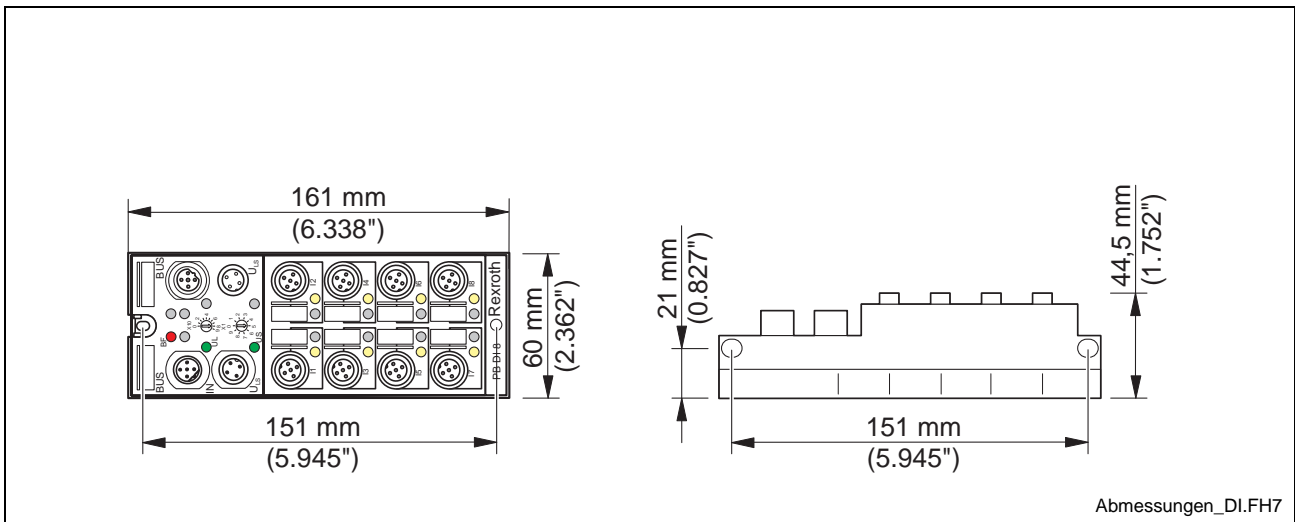

Fig. 4-4: Device dimensions

General Data

Housing dimensions (width x height x depth)	60 mm x 161 mm x 44.5 mm (2.362 in. x 6.338 in. x 1.752 in.)	
Weight	310 g, approximately	
Operating mode	Process data operation with 8 bits	
Type of sensor connection	2-, 3- or 4-wire technology	
Permissible temperature	Operation	-25 °C to +60 °C (-13 °F to +140 °F)
	Storage/transport	-25 °C to +85 °C (-13 °F to +185 °F)
Permissible humidity	Storage/transport	95 %

Note: For a short period, slight condensation may appear on the housing.

Permissible air pressure	Operation	80 kPa to 106 kPa (up to 2000 m [6562 ft.] above sea level)
	Storage/transport	70 kPa to 106 kPa (up to 3000 m [9843 ft.] above sea level)
Degree of protection	IP 65 / IP 67 according to IEC 60529	
Class of protection	Class 3 according to VDE 0106, IEC 60536	

Fig. 4-5: General data

Mechanical Demands

Vibration test sinusoidal vibrations according to EN 60068-2-6	5 g load for each space direction
Shock test according to EN 60068-2-27	30 g load, half sinusoidal wave, positive and negative for each space direction

Fig. 4-6: Mechanical demands

Voltage Supply

Nominal value	24 V DC
Range	18 V DC to 30 V DC
Current consumption U_L at 24 V DC	35 mA, typical (100 mA, maximum)
Current consumption U_S at 24 V DC	4.5 mA, typical + sensor current (700 mA, maximum)

Fig. 4-7: Voltage supply

Digital Inputs

Number	8
Input design	According to IEC 61131-2 Type 1
Definition of switching thresholds	
Maximum low level voltage	$U_{Lmax} < 5 \text{ V}$
Minimum high level voltage	$U_{Hmin} > 11 \text{ V}$
Nominal input voltage	24 V DC
Range	$-30 \text{ V DC} < U_{IN} < +30 \text{ V DC}$
Nominal input current	5 mA
Characteristic curve of the current	Linear in the range $1 \text{ V} < U_{IN} < 30 \text{ V}$
Delay time	$t_{ON} = 3.1 \text{ ms}$, typical $t_{OFF} = 4.1 \text{ ms}$, typical
Permissible cable length to the sensor	100 m (328 ft.)

Fig. 4-8: Digital inputs

Input Characteristic Curve

Input voltage (V)	Typical input current (mA)
$-30 < U_{IN} < 0.7$	0
3	0.5
6	1.0
9	1.6
12	2.3
15	3.0
18	3.8
21	4.5
24	5.2
27	6.0
30	6.7

Fig. 4-9: Input characteristic curve

Sensor Supply

Minimum sensor voltage	$U_S - 1V$
Nominal current per channel	75 mA
Nominal current per device	600 mA
Overload protection	Electronically per device
Short-circuit protection	Electronically per device

Fig. 4-10: Sensor supply

Error Message to the Higher-Level Control or Computer System

Short-circuit of sensor supply	Yes
Overload of sensor supply	Yes

Fig. 4-11: Error messages to the higher level control or computer system

Note: If an error is triggered by an overload or short-circuit of the sensor supply, the device switches off the sensor supply of the channels and sends an error message to the master.

If the sensor supply U_S is not sufficiently high, the device sends an error message to the master (see Diagnostic Data on page 4-14).

Interfaces

Interface	
Bus system	PROFIBUS DP

Fig. 4-12: Interface 'Bus system'

Incoming bus	
Coupling of shield connection	Directly to FE
Transmission rate	12 Mbaud, maximum

Fig. 4-13: Interface 'Incoming bus'

Outgoing bus	
Coupling of shield connection	Directly to FE
Transmission rate	12 Mbaud, maximum

Fig. 4-14: Interface 'Outgoing bus'

Note: Because of the integrated series inductance the device can be operated with up to 12 Mbaud without additional external components. A wiring with T-pieces is not supported.

Electrical Isolation/Isolation of the Voltage Areas

Note: For device connection, please note the instructions and regulations in the application description DOK-CONTRL-RF-FLS-PB**-AW...-EN-P.

Separate potentials in the FLS PB M12 DI 8 M12 input device	
- Test distance	- Test voltage
24 V supply (bus logic) / bus connection	500 V AC, 50 Hz, 1 min
24 V supply (bus logic) / FE	500 V AC, 50 Hz, 1 min
24 V supply (bus logic) / digital inputs (sensor supply)	500 V AC, 50 Hz, 1 min
Bus connection / FE	500 V AC, 50 Hz, 1 min
Bus connection / digital inputs (sensor supply)	500 V AC, 50 Hz, 1 min
FE / digital inputs (sensor supply)	500 V AC, 50 Hz, 1 min

Fig. 4-15: Electrical isolation/Isolation of the voltage areas

4.3 Connections

Connections of the Device

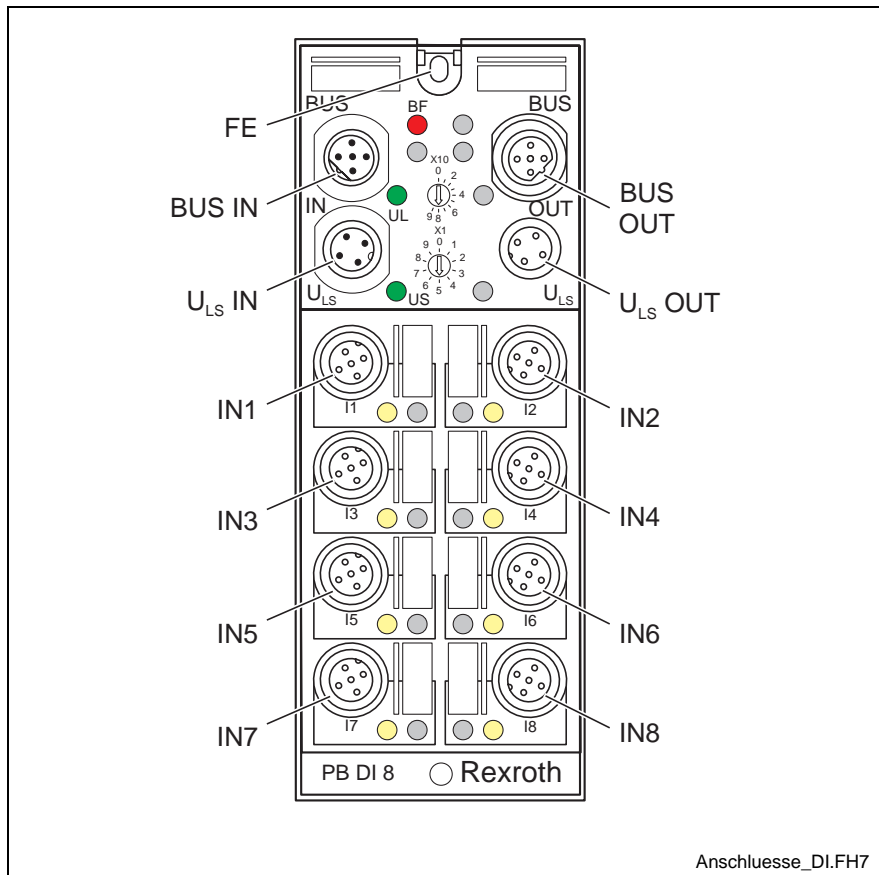

Fig. 4-16: Connections of the device

Pin Assignment

Des.	Meaning
FE	Functional earth ground
BUS IN	PROFIBUS IN
BUS OUT	PROFIBUS OUT
U _{LS} IN	Voltage supply IN (logic and sensor supply)
U _{LS} OUT	Voltage supply OUT (logic and sensor supply) for additional devices
IN1 to IN8	Inputs 1 to 8

Fig. 4-17: Pin assignment

PROFIBUS Pin Assignment

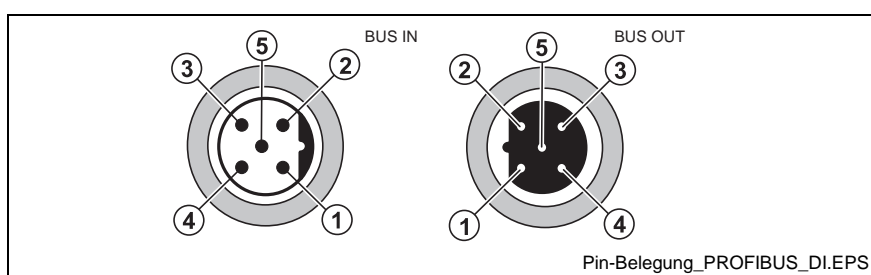

Fig. 4-18: PROFIBUS pin assignment (encoded according to M12 B)

Pin	IN	OUT
1	VP	VP
2	RxD/TxD-N (A)	RxD/TxD-N (A)
3	DGND	DGND
4	RxD/TxD-P (B)	RxD/TxD-P (B)
5	Shield	Shield

Fig. 4-19: PROFIBUS pin assignment (encoded according to M12 B)

Note: The thread is used for additional shielding.

Pin Assignment of the Voltage Supply U_{LS}

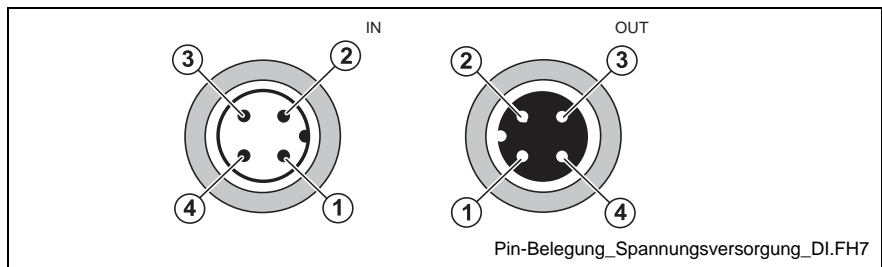

Fig. 4-20: Pin assignment of the voltage supply U_{LS}

Pin	IN	OUT
1	$U_L +24 V$	$U_L +24 V$
2	$U_S GND$	$U_S GND$
3	$U_L GND$	$U_L GND$
4	$U_S +24V$	$U_S +24V$

Fig. 4-21: Pin assignment of the voltage supply U_{LS}

Pin Assignment of the Inputs

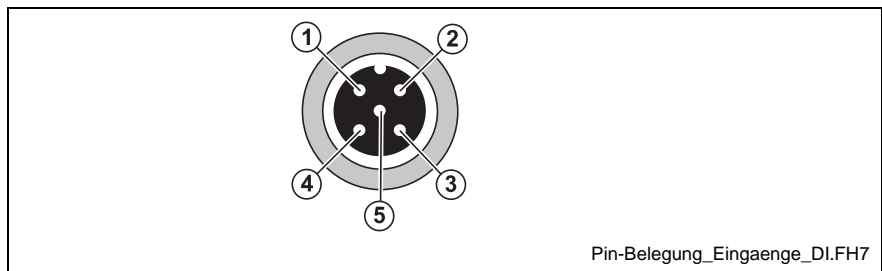

Fig. 4-22: Pin assignment of the inputs

Pin	Input socket
1	$U_S +24 V$
2	See Fig. 4-24
3	GND
4	Input
5	FE

Fig. 4-23: Pin assignment of the inputs

Assignment of the Input Sockets

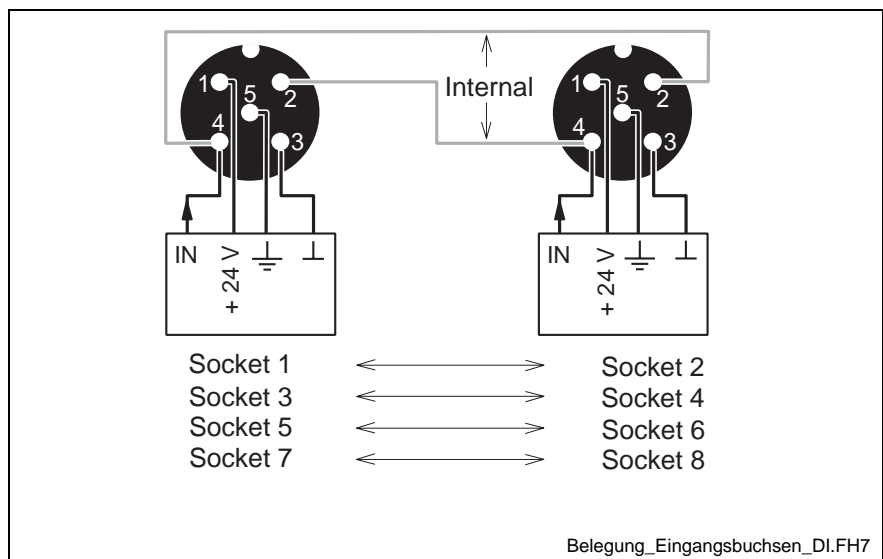

Fig. 4-24: Assignment of the input sockets

Note: Two input signals can be connected to each input socket. If both inputs of the same socket are used, the other socket must not be used (1 or 2, 3 or 4, 5 or 6, 7 or 8).

Internal Circuit Diagram

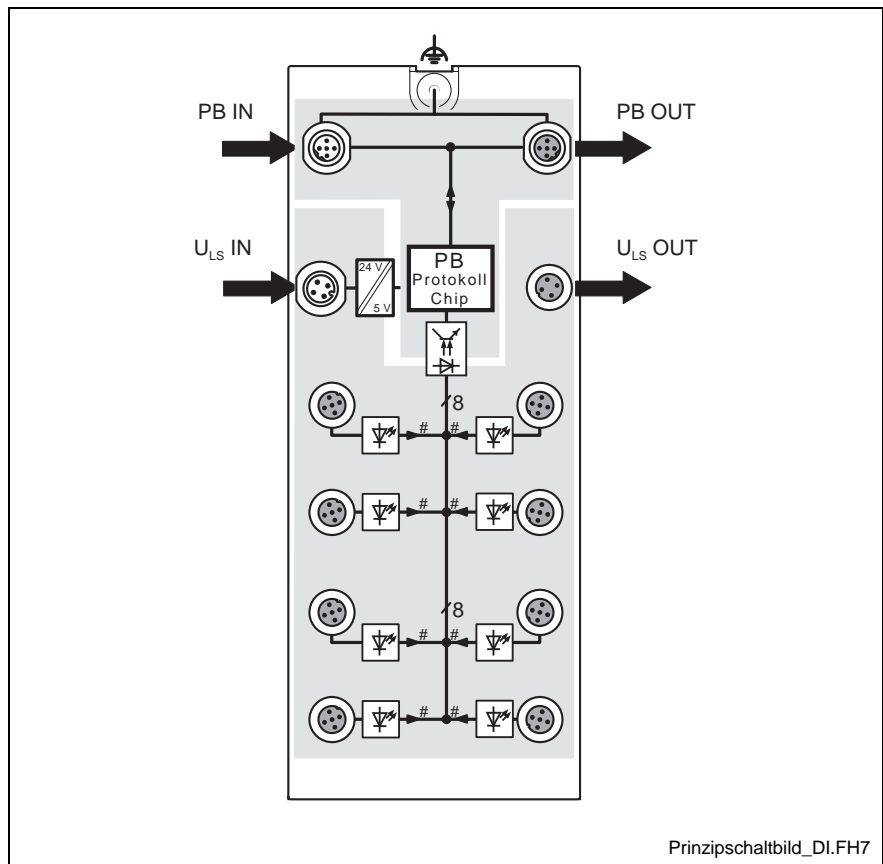

Fig. 4-25: Internal wiring of the connection points

Key

Symbol	Meaning
	Functional earth ground
	Isolating transformer
	PROFIBUS protocol chip (bus logic including voltage conditioning)
	Optocoupler
	LED
	Input
	Electrically isolated area (for this, see also section Electrical Isolation/Isolation of the Voltage Areas on page 4-7)

Fig. 4-26: Key

Connection Example

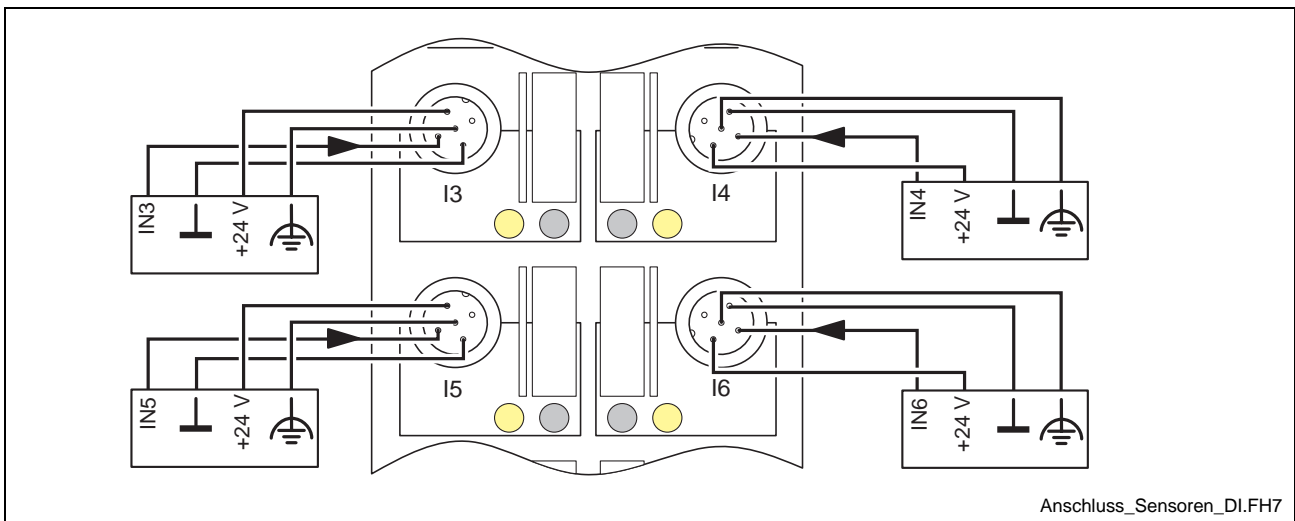

Fig. 4-27: Sensor connection example

Connection Notes

Note: Meet noise immunity requirements

Connect FE using a mounting screw or a cable connection to the FE connection link (when mounting on the side or on a non-conductive surface).

Note: Ensure degree of IP protection

To ensure IP 65 / IP 67 protection, cover unused sockets with protective caps.

Note: Avoid damage to the electronics

Make sure you only supply the sensors with the voltage U_S provided at the connection points.

Note: Avoid polarity reversal

Avoid polarity reversal of the supply voltages U_L , U_S and U_A to avoid damage to the device.

Note: Observe connection point assignment

When connecting the sensors, observe the assignment of the connection points to the PROFIBUS input data (see Process Data on page 4-13).

Configuration Data

ID number	066B _{hex}
Input address area	8 bits

Fig. 4-28: Configuration data

Process Data

Assignment of connection points to the IN process data

(Byte.Bit) view	Byte	Byte 0							
	Bit	7	6	5	4	3	2	1	0
Device	Input	8	7	6	5	4	3	2	1

Fig. 4-29: IN process data

Diagnostic Data

Mapping of diagnostic data in PROFIBUS

Diagnostic data	Bit 7	Bit 6	Bit 5	Bit 4	Bit 3	Bit 2	Bit 1	Bit 0	Remark
Byte 0	X	X	X	X	X	X	X	X	Station status 1
Byte 1	X	X	X	X	X	X	X	X	Station status 2
Byte 2	X	X	X	X	X	X	X	X	Station status 3
Byte 3	X	X	X	X	X	X	X	X	Master address diagnostics
Byte 4	0	0	0	0	0	1	1	0	High ID number
Byte 5	0	1	1	0	1	0	1	1	Low ID number
Byte 6	0	0	0	0	0	1	1	1	Diagnostic header
Byte 7	M.7	M.6	M.5	M.4	M.3	M.2	M.1	M.0	Device diagnostics
Byte 8	0	0	0	0	0	0	0	0	Reserved
Byte 9	0	0	0	0	0	0	0	0	Reserved
Byte 10	0	0	0	0	0	0	0	0	Reserved
Byte 11	0	0	0	0	0	0	0	0	Reserved
Byte 12	X	X	0	0	0	0	0	0	Reserved

Fig. 4-30: Diagnostic data

Note: Bytes 0 to 6 are PROFIBUS standard. Bytes 7 to 12 are device-specific.

Diagnostic data for device diagnostics

Bit	Remark	Assignment
M.0-M.2	Reserved	0
M.3	Status of the U_S sensor supply	1, if sensor supply too low
M.4-M.5	Reserved	0
M.6	Status of the U_L device supply	1, if device supply too low
M.7	Overload status of the U_S sensor supply	1, if sensor supply overloaded

Fig. 4-31: Diagnostic data for device diagnostic

Note: If a diagnostic event occurs, the diagnostic data is sent to the master by means of a diagnostic telegram generated once by the device.

The current diagnostic data status can be read by the device at any time.

5 Stand Alone Device for PROFIBUS DP with 4 Digital Outputs and Inputs

5.1 Presentation and Intended Use

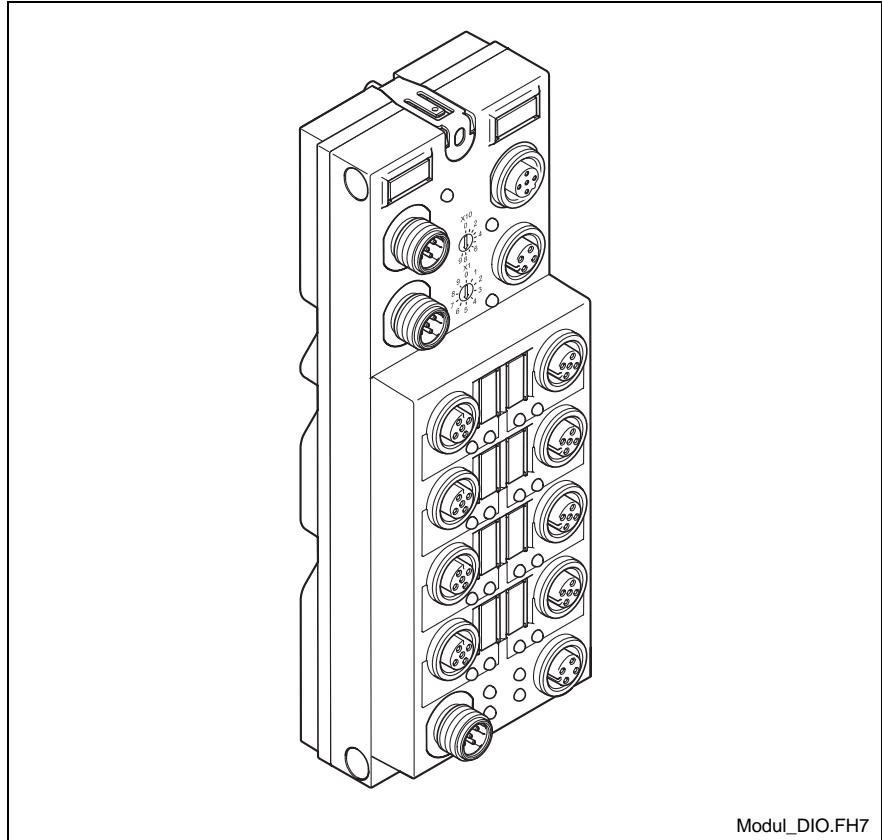

Fig. 5-1: RECO Fieldline device RF-FLS PB M12 DIO 4/4 M12-2A

This device is used for digital data acquisition and output.

Features

- Connection to PROFIBUS DP using M12 connectors (B-encoded)
- Baud rate with up to 12 Mbaud autobaud
- Connection of digital sensors using M12 connectors
- Connection of digital actuators using M12 connectors, each with a load capacity of 2 A (nominal current)
- Flexible voltage supply concept
- Diagnostic and status indicators
- Short-circuit and overload protection of outputs and sensor supply
- IP 65 / IP 67 degrees of protection

Indicator Elements

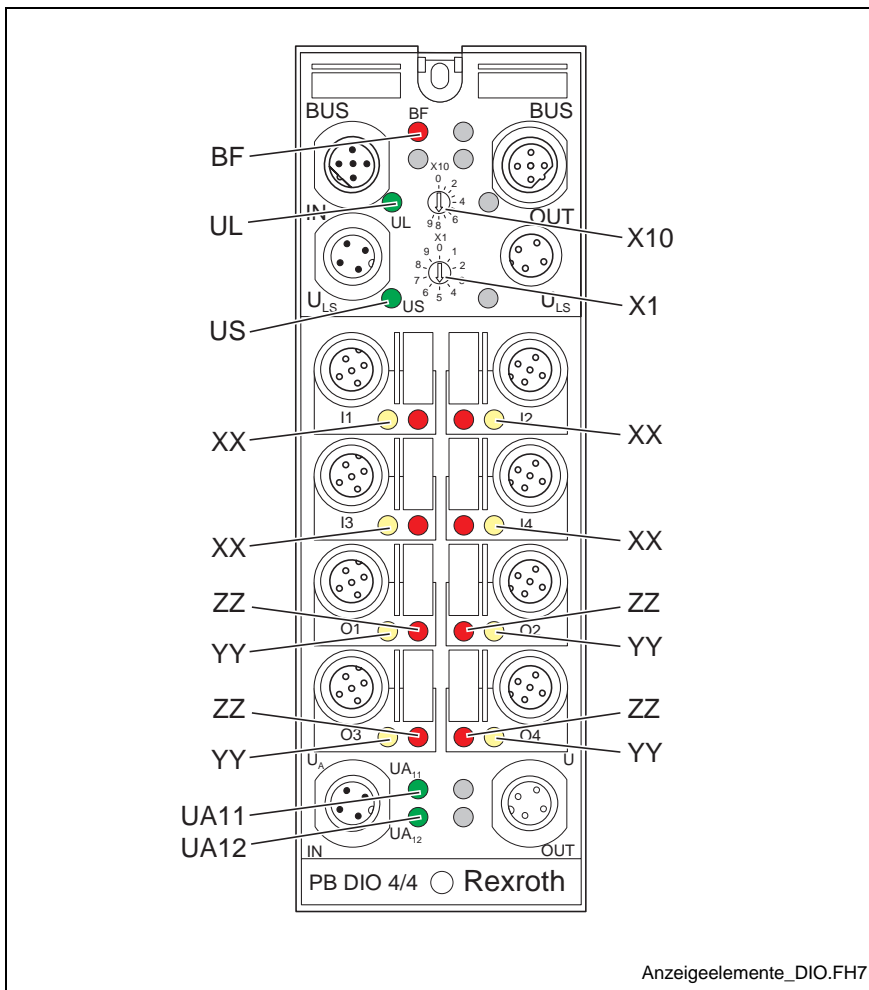

Fig. 5-2: Diagnostic and status indicators

Rotary Encoding Switches

The station address is set using the rotary encoding switches X10 (for the first digit of a two-digit number) and X1 (for the second digit of a two-digit number). The PROFIBUS master addresses the device by means of this station address.

Note: The valid value range is between 1 and 99.
A new address value is only accepted upon device power-up.

Des.	Color	Meaning
BF	Red LED:	Bus failure
	ON:	No cyclic data transmission: <ul style="list-style-type: none"> • PROFIBUS not connected, master not active • Incorrect settings (configuration via master, station address) • Synchronization or parameterization running • Timeout expired
	OFF:	<ul style="list-style-type: none"> • Device is addressed by PROFIBUS and is in the "cyclic process data exchange" state • Missing device supply (In this state the "UL" LED is also off because of missing 24 V communications voltage.)
UL	Green LED:	Communications power
	ON:	Communications power present
	OFF:	Communications power too low
US	Red/green LED:	Voltage supply for input IN1 to IN4
	ON (red):	Voltage supply overloaded
	ON (green):	Voltage supply present
	OFF:	Voltage supply too low
XX	Yellow LED:	Status indicators of the inputs
	ON:	Input active
	OFF:	Input not active
YY	Yellow LED:	Status indicators of the outputs
	ON:	Output active
	OFF:	Output not active
ZZ	Red LED:	Overload of outputs
	ON:	Output overloaded
	OFF:	Output not overloaded
UA11	Green LED:	Voltage supply for OUT1 and OUT2
	ON:	Voltage supply for OUT1 and OUT2 present
	OFF:	Voltage supply for OUT1 and OUT2 too low
UA12	Green LED:	Voltage supply for OUT3 and OUT4
	ON:	Voltage supply for OUT3 and OUT4 present
	OFF:	Voltage supply for OUT3 and OUT4 too low

Fig. 5-3: Local diagnostic and status indicators

5.2 Technical Data

Device Dimensions

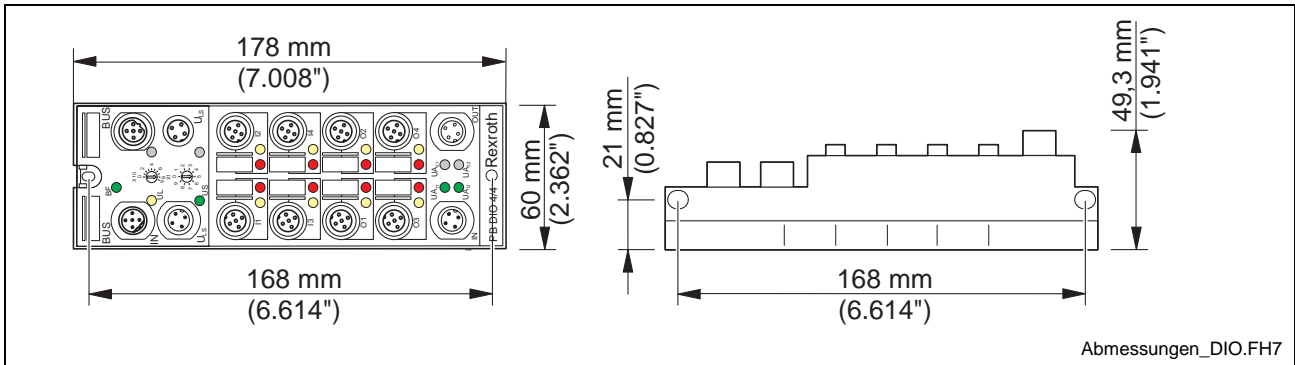

Fig. 5-4: Device dimensions

General Data

Housing dimensions (width x height x depth)	60 mm x 178 mm x 49.3 mm (2.362 in. x 7.008 in. x 1.941 in.)	
Weight	340 g, approximately	
Operating mode	Process data operation with 8 bits	
Type of sensor connection	2-, 3- or 4-wire technology	
Type of actuator connection	2- or 3-wire technology	
Permissible temperature	Operation	-25 °C to +60 °C (-13 °F to +140 °F)
	Storage/transport	-25 °C to +85 °C (-13 °F to +185 °F)
Permissible humidity	Storage/transport	95 %

Note: For a short period, slight condensation may appear on the housing.

Permissible air pressure	Operation	80 kPa to 106 kPa (up to 2000 m [6562 ft.] above sea level)
	Storage/transport	70 kPa to 106 kPa (up to 3000 m [9843 ft.] above sea level)
Degree of protection	IP 65 / IP 67 according to IEC 60529	
Class of protection	Class 3 according to VDE 0106, IEC 60536	

Fig. 5-5: General data

Mechanical Demands

Vibration test sinusoidal vibrations according to EN 60068-2-6	5 g load for each space direction
Shock test according to EN 60068-2-27	30 g load, half sinusoidal wave, positive and negative for each space direction

Fig. 5-6: Mechanical demands

Voltage Supply

Nominal value	24 V DC
Range	18 V DC to 30 V DC
Current consumption I_L at 24 V DC	40 mA, typical (100 mA, maximum)
Current consumption I_S at 24 V DC	4.5 mA, typical + sensor current (700 mA, maximum)
Current consumption I_{AAX} at 24 V DC	6 mA, typical + actuator current (4 A, maximum)

Fig. 5-7: Voltage supply

Digital Inputs

Number	4
Input design	According to IEC 61131-2 Type 1
Definition of switching thresholds	
Maximum low level voltage	$U_{Lmax} < 5 V$
Minimum high level voltage	$U_{Hmin} > 11 V$
Nominal input voltage	24 V DC
Range	$-30 V DC < U_{IN} < +30 V DC$
Nominal input current	5 mA
Characteristic curve of the current	Linear in the range $1 V < U_{IN} < 30 V$
Delay time	$t_{ON} = 3.1 ms$, typical $t_{OFF} = 4.1 ms$, typical
Permissible cable length to the sensor	100 m (328 ft.)

Fig. 5-8: Digital inputs

Input Characteristic Curve

Input voltage (V)	Typical input current (mA)
$-30 < U_{IN} < 0.7$	0
3	0.5
6	1.0
9	1.6
12	2.3
15	3.0
18	3.8
21	4.5
24	5.2
27	6.0
30	6.7

Fig. 5-9: Input characteristic curve

Sensor Supply

Minimum sensor voltage	$U_S - 1 \text{ V}$
Nominal current per channel	75 mA
Nominal current per device	300 mA
Overload protection	Electronically per device
Short-circuit protection	Electronically per device

Fig. 5-10: Sensor supply

Error Messages to the Higher-Level Control or Computer System

Sensor supply short-circuit	Yes
Sensor supply overload	Yes

Fig. 5-11: Error messages to the higher-level control or computer system

Note: If an error is triggered by an overload or short-circuit of the sensor supply, the device switches off the sensor supply of the channels and sends an error message to the master.
If the sensor supply U_S is not sufficiently high, the device sends an error message to the master (see Diagnostic Data on page 5-18).

Digital Outputs

Number	4
Nominal output voltage U_{OUT}	$U_{AXX} - 1 \text{ V}$
Differential voltage for I_{nom}	$\leq 1 \text{ V}$
Nominal current I_{nom} per channel	2 A
Total current	8 A (observe derating)
Possible output current during short-circuit	22 A, maximum for 300 μs

Note: Please take this value into account, when selecting the power supply unit.

Protection	Short-circuit; overload
------------	-------------------------

Note: Single chip structure, i.e., all channels are thermally isolated.

Derating with 100 % simultaneity

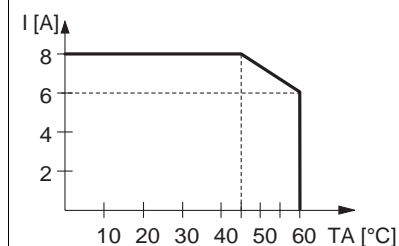

Digital outputs	
Nominal load per channel	
<ul style="list-style-type: none"> • Ohmic • Inductive • Lamps 	<p>48 W</p> <p>48 VA (1,2 H, 12 Ω)</p> <p>48 W</p>
Signal delay upon power-up of	
<ul style="list-style-type: none"> • Ohmic nominal load • Inductive nominal load • Lamp load 	<p>Approximately 200 μs, typical</p> <p>Depending on inductive time constant</p> <p>Approximately 200 μs, typical</p>
Signal delay upon power-down of	
<ul style="list-style-type: none"> • Ohmic nominal load • Inductive nominal load • Lamp nominal load 	<p>250 μs, approximately</p> <p>Approximately 150 ms (1.2 H, 12 Ω), depending on inductive time constant</p> <p>250 μs, approximately</p>
Switching frequency with	
<ul style="list-style-type: none"> • Ohmic nominal load 	500 Hz, maximum
<p>Note: This switching frequency is limited by the number of bus devices, the bus structure, the software, and the control or computer system used.</p>	
<ul style="list-style-type: none"> • Inductive nominal load • Lamp nominal load 	<p>0.1 Hz, maximum (1.2 H, 12 Ω)</p> <p>500 Hz, maximum</p>
Overload response	Auto restart
Restart frequency with ohmic overload (2 Ω)	45 Hz, approximately
Inductive overload response	Output may be damaged
Reverse voltage endurance against short pulses	Protected against reverse voltages
Resistance to permanently applied reverse voltages	No
Response upon power-down	The output follows the supply voltage without delay.
Validity of output data after connecting the voltage supply (power-up)	5 ms, typical
Limitation of the voltage induced on circuit interruption	-11 V, approximately
Single maximum energy in free running	1500 W
Protective circuit type	Integrated free-wheeling diode for each channel
Overcurrent shutdown	At 2.6 A, minimum
Output current when switched off	20 μA, maximum
Output current with ground connection interrupt when switched off	5 mA, maximum

Fig. 5-12: Digital outputs

Error Messages

Overload of outputs	Yes
---------------------	-----

Fig. 5-13: Error messages

Note: If an error is triggered at the outputs due to an overload, the device switches off the corresponding output and sends an error message to the master (see section Diagnostic Data on page 5-18).

Output Characteristic Curve When Switched ON (Typical)

Output current (A)	Differential output voltage (V)
0	0
0.20	0.01
0.40	0.03
0.75	0.05
1.00	0.07
1.50	0.12
1.75	0.13
2.00	0.17

Fig. 5-14: Output characteristic curve when switched ON

Output Characteristic Curve When Switched OFF ($U_{AXX} = 30$ V DC; Typical)

Load resistance (k Ω)	Output voltage (V)
∞	1.5
1000	0.9
100	0.1
10	0.01
1	0.001

Fig. 5-15: Output characteristic curve when switched OFF

Output Characteristic Curve for Ground Connection Interrupt ($U_{AXX} = 30$ V DC; Typical)

Load resistance (k Ω)	Output voltage (V)
∞	29,9
1000	28,8
100	25,0
10	13,6
1	3,8

Fig. 5-16: Output characteristic curve for ground connection interrupt

Interfaces

Interface	
Bus system	PROFIBUS DP

Fig. 5-17: Interface 'Bus system'

Incoming bus	
Coupling of shield connection	Directly to FE
Transmission rate	12 Mbaud, maximum

Fig. 5-18: Interface 'Incoming bus'

Outgoing bus	
Coupling of shield connection	Directly to FE
Transmission rate	12 Mbaud, maximum

Fig. 5-19: Interface 'Outgoing bus'

Note: Because of the integrated series inductance the device can be operated with up to 12 Mbaud without additional external components. A wiring with T-pieces is not supported.

Electrical Isolation/Isolation of the Voltage Areas

Note: For device connection, please note the instructions and regulations in the application description DOK-CONTRL-RF-FLS-PB**-AW...-EN-P.

Separate potentials in the RF FLS PB M12 DIO 4/4 M12-2A I/O device	
- Test Distance	- Test voltage
24 V supply (bus logic) / bus connection	500 V AC, 50 Hz, 1 min
24 V supply (bus logic) / FE	500 V AC, 50 Hz, 1 min
24 V supply (bus logic) / digital inputs (sensor supply)	500 V AC, 50 Hz, 1 min
24 V supply (bus logic) / digital outputs (actuator supply)	500 V AC, 50 Hz, 1 min
Bus connection / FE	500 V AC, 50 Hz, 1 min
Bus connection / digital inputs (sensor supply)	500 V AC, 50 Hz, 1 min
Bus connection / digital outputs (actuator supply)	500 V AC, 50 Hz, 1 min
FE / digital inputs (sensor supply)	500 V AC, 50 Hz, 1 min
FE / digital outputs (actuator supply)	500 V AC, 50 Hz, 1 min
Digital outputs (actuator supply) / digital outputs (actuator supply)	500 V AC, 50 Hz, 1 min

Fig. 5-20: Electrical isolation/Isolation of the voltage areas

5.3 Connections

Connections of the Device

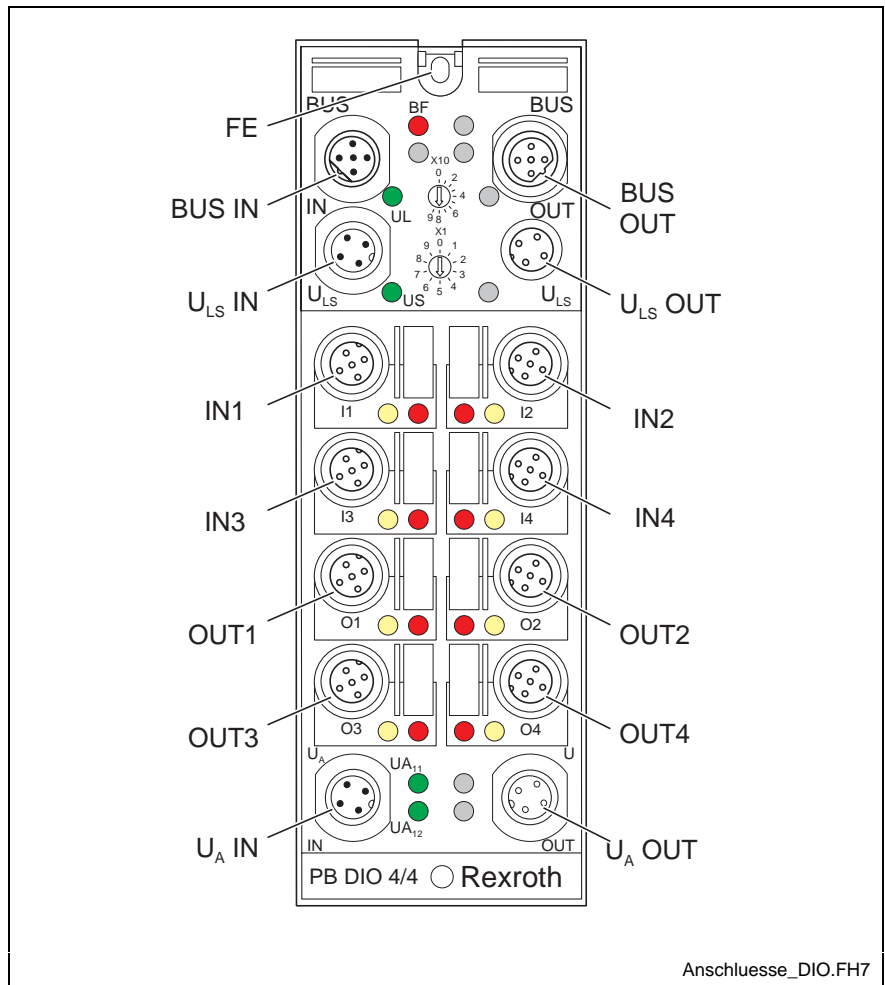

Fig. 5-21: Device connections RF-FLS PB M12 DIO 4/4 M12-2A

Pin Assignment

Des.	Meaning
FE	Functional earth ground
BUS IN	PROFIBUS IN
BUS OUT	PROFIBUS OUT
U _{LS} IN	Voltage supply IN (logic and sensor supply)
U _{LS} OUT	Voltage supply OUT (logic and sensor supply) for additional devices
IN1 to IN4	Input 1 to 4
OUT1 to OUT4	Output 1 to 4
U _A IN	Voltage supply IN of the outputs (OUT1 to OUT4) with voltage U _{A11} and U _{A12}
U _A OUT	Voltage supply OUT of the outputs for additional devices

Fig. 5-22: Pin assignment

PROFIBUS Pin Assignment

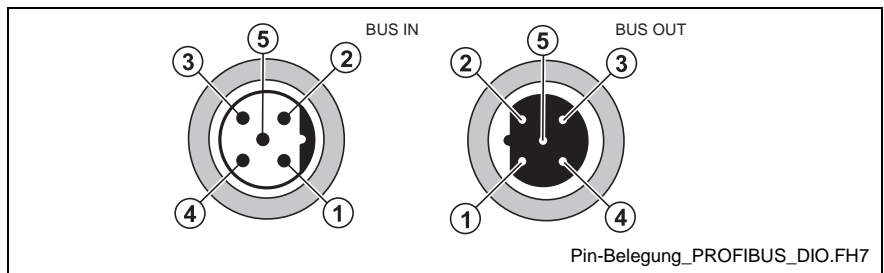

Fig. 5-23: PROFIBUS pin assignment (encoded according to M12 B)

Pin	IN	OUT
1	VP	VP
2	RxD/TxD-N (A)	RxD/TxD-N (A)
3	DGND	DGND
4	RxD/TxD-P (B)	RxD/TxD-P (B)
5	Shield	Shield

Fig. 5-24: PROFIBUS pin assignment (encoded according to M12 B)

Note: The thread is used for additional shielding.

Pin Assignment of the Voltage Supply U_{LS}

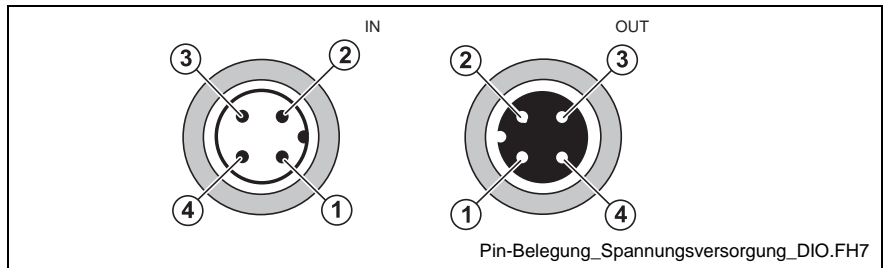

Fig. 5-25: Pin assignment of the voltage supply U_{LS}

Pin	IN	OUT
1	$U_L +24 V$	$U_L +24 V$
2	$U_S GND$	$U_S GND$
3	$U_L GND$	$U_L GND$
4	$U_S +24 V$	$U_S +24 V$

Fig. 5-26: Pin assignment of the voltage supply U_{LS}

Pin Assignment of the Voltage Supply U_A of the Outputs

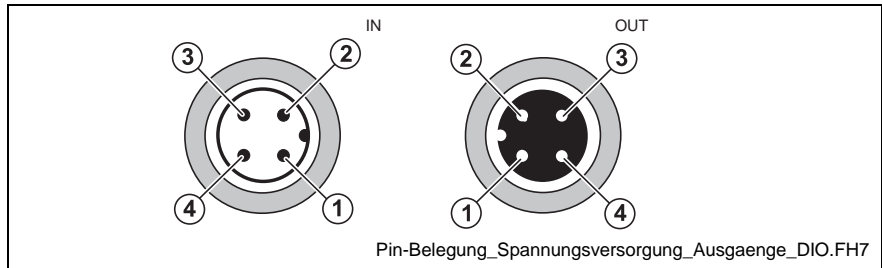

Fig. 5-27: Pin assignment of the voltage supply U_A of the outputs

Pin	IN	OUT
1	$U_{A11} +24\text{ V}$	$U_{A11} +24\text{ V}$
2	$U_{A12}\text{ GND}$	$U_{A12}\text{ GND}$
3	$U_{A11}\text{ GND}$	$U_{A11}\text{ GND}$
4	$U_{A12} +24\text{ V}$	$U_{A12} +24\text{ V}$

Fig. 5-28: Pin assignment of the voltage supply U_A of the outputs

Pin Assignment of the Inputs and Outputs

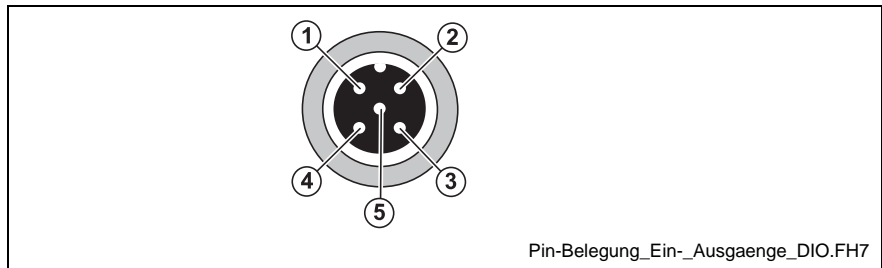

Fig. 5-29: Pin assignment of the inputs and outputs

Pin	Input socket	Output socket
1	$U_S +24\text{ V}$	Not used
2	See Fig. 5-31	Not used
3	GND	GND
4	Input	Output
5	FE	FE

Fig. 5-30: Pin assignment of the inputs and outputs

Assignment of the Input Sockets

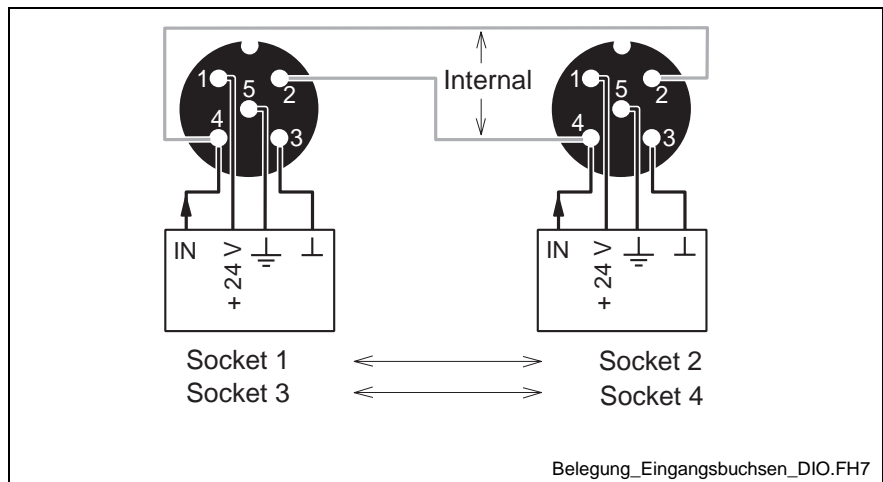

Fig. 5-31: Assignment of the input sockets

Note: Two input signals can be connected to each input socket. If both inputs of the same socket are used, the other socket must not be used (1 or 2 or 3 or 4).

Internal Circuit Diagram

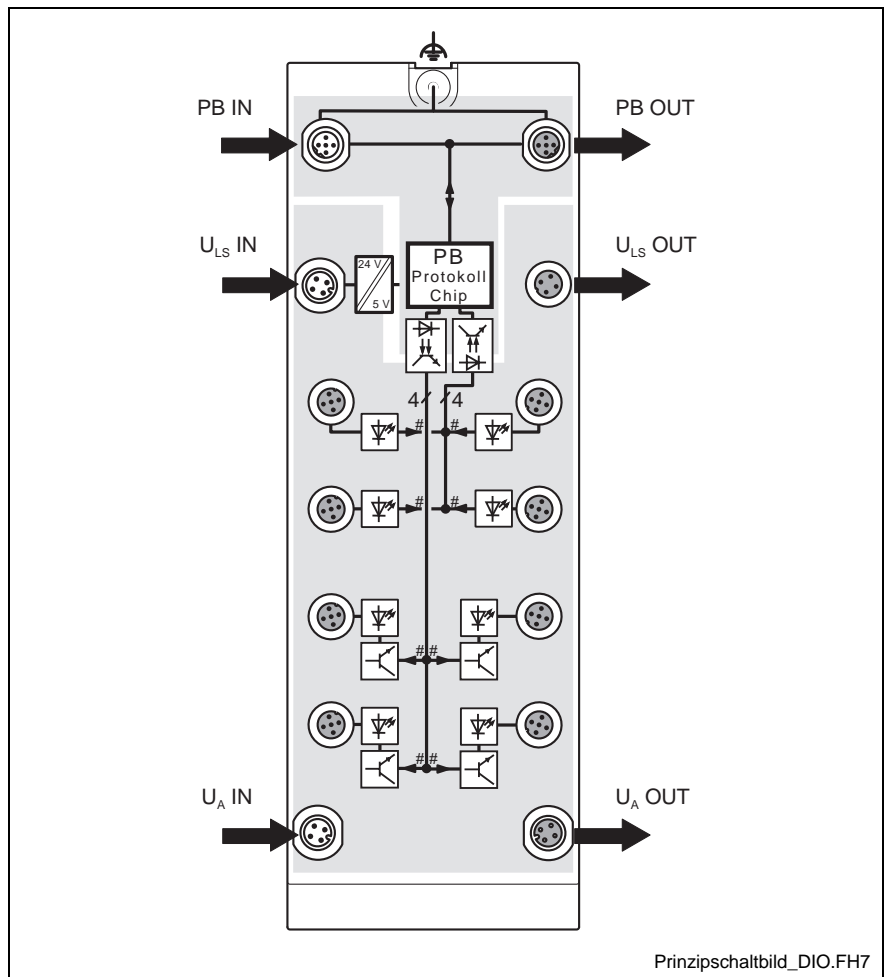

Fig. 5-32: Internal wiring of the connection points

Key









Symbol	Meaning
	Functional earth ground
	Isolating transformer
	PROFIBUS protocol chip (bus logic including voltage conditioning)
	Optocoupler
	LED
	Transistor
	Input
	Output
	Electrically isolated area (for this, see also section Electrical Isolation/Isolation of the Voltage Areas on page 5-9)

Fig. 5-33: Key

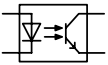
Connection Example

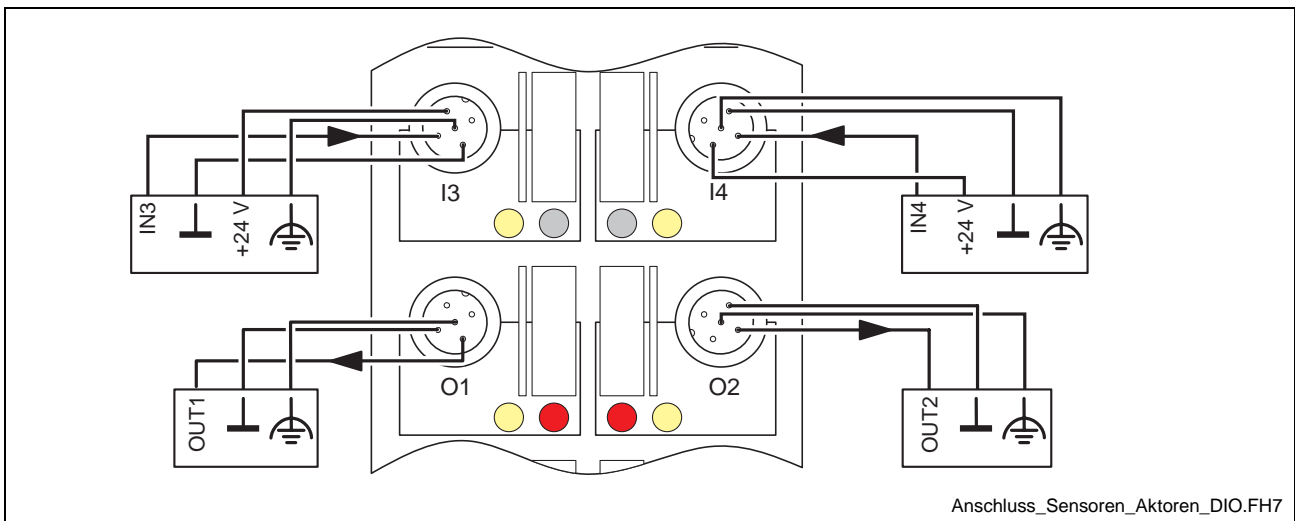

Fig. 5-34: Sensor and actuator connection example

Connection Notes

Note: Meet noise immunity requirements

Connect FE using a mounting screw or a cable connection to the FE connection link (when mounting on the side or on a non-conductive surface).

Note: Ensure degree of IP protection

To ensure IP 65 / IP 67 protection, cover unused sockets with protective caps.

Note: Avoid damage to the electronics

Make sure you only supply the sensors with the voltage U_S provided at the connection points.

Note: Avoid polarity reversal

Avoid polarity reversal of the supply voltages U_L , U_S and U_A to avoid damage to the device.

Note: Observe connection point assignment

When connecting the sensors and actuators, observe the assignment of the connection points to the PROFIBUS input and output data (see Process Data on page 5-17).

Configuration Data

ID number	066A _{hex}
Input address area	8 bits
Output address area	8 bits

Fig. 5-35: Configuration data

Process Data

Assignment of connection points to the IN process data

(Byte.Bit) view	Byte	Byte 0							
	Bit	7	6	5	4	3	2	1	0
Device	Input	0	0	0	0	4	3	2	1

Fig. 5-36: IN process data

Note: For bits 0.4 to 0.7 of the inputs the value is "0".

Assignment of connection points to the OUT process data

(Byte.Bit) view	Byte	Byte 0							
	Bit	7	6	5	4	3	2	1	0
Device	Output	X	X	X	X	4	3	2	1

Fig. 5-37: OUT process data

Note: The assignment of the bits 0.4 to 0.7 of the outputs has no effect on the output state.

Diagnostic Data

Mapping of the diagnostic data in PROFIBUS

Diagnostic data	Bit 7	Bit 6	Bit 5	Bit 4	Bit 3	Bit 2	Bit 1	Bit 0	Remark
Byte 0	X	X	X	X	X	X	X	X	Station status 1
Byte 1	X	X	X	X	X	X	X	X	Station status 2
Byte 2	X	X	X	X	X	X	X	X	Station status 3
Byte 3	X	X	X	X	X	X	X	X	Master address diagnostics
Byte 4	0	0	0	0	0	1	1	0	High ID number
Byte 5	0	1	1	0	1	0	1	0	Low ID number
Byte 6	0	0	0	0	0	1	1	1	Diagnostic header
Byte 7	M.7	M.6	M.5	M.4	M.3	M.2	M.1	M.0	Device diagnostics
Byte 8	0	0	0	0	0	0	0	0	Reserved
Byte 9	0	0	0	0	0	0	0	0	Reserved
Byte 10	0	0	0	0	0	0	0	0	Reserved
Byte 11	0	0	0	0	0	0	0	0	Reserved
Byte 12	X	X	0	0	0	0	0	0	Reserved

Fig. 5-38: Diagnostic data

Note: Bytes 0 to 6 are PROFIBUS standard. Bytes 7 to 12 are device-specific.

Diagnostic data for device diagnostics

Bit	Remark	Assignment
M.0-M.2	Reserved	0
M.3	Status of the U_S sensor supply	1, if sensor supply too low
M.4	Reserved	0
M.5	Overload status of the outputs	OUT1 to OUT4
M.6	Status of the U_L device supply	1, if device supply too low
M.7	Overload status of the U_S sensor supply	1, if sensor supply overloaded

Fig. 5-39: Diagnostic data for device diagnostics

Note: If a diagnostic event occurs, the diagnostic data is sent to the master by means of a diagnostic telegram generated once by the device.
The current diagnostic data status can be read by the device at any time.

6 Stand Alone Device for PROFIBUS DP with 8 Digital Outputs

6.1 Presentation and Intended Use

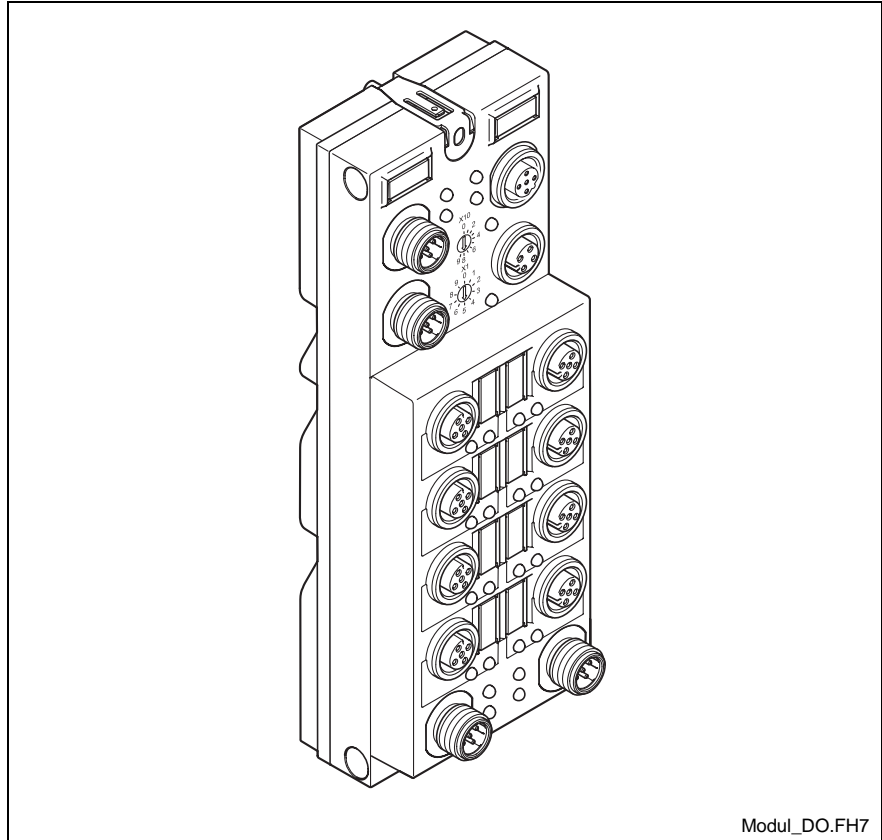

Fig. 6-1: RECO Fieldline device RF-FLS PB M12 DO 8 M12-2A

This device is used for digital signal output.

Features

- Connection to PROFIBUS DP using M12 connectors (B-encoded)
- Baud rate with up to 12 Mbaud autobaud
- Connection of digital actuators using M12 connectors, each with a load capacity of 2 A (nominal current)
- Flexible voltage supply concept
- Diagnostic and status indicators
- Short-circuit and overload protection of outputs
- IP 65/IP 67 degrees of protection

Indicator Elements

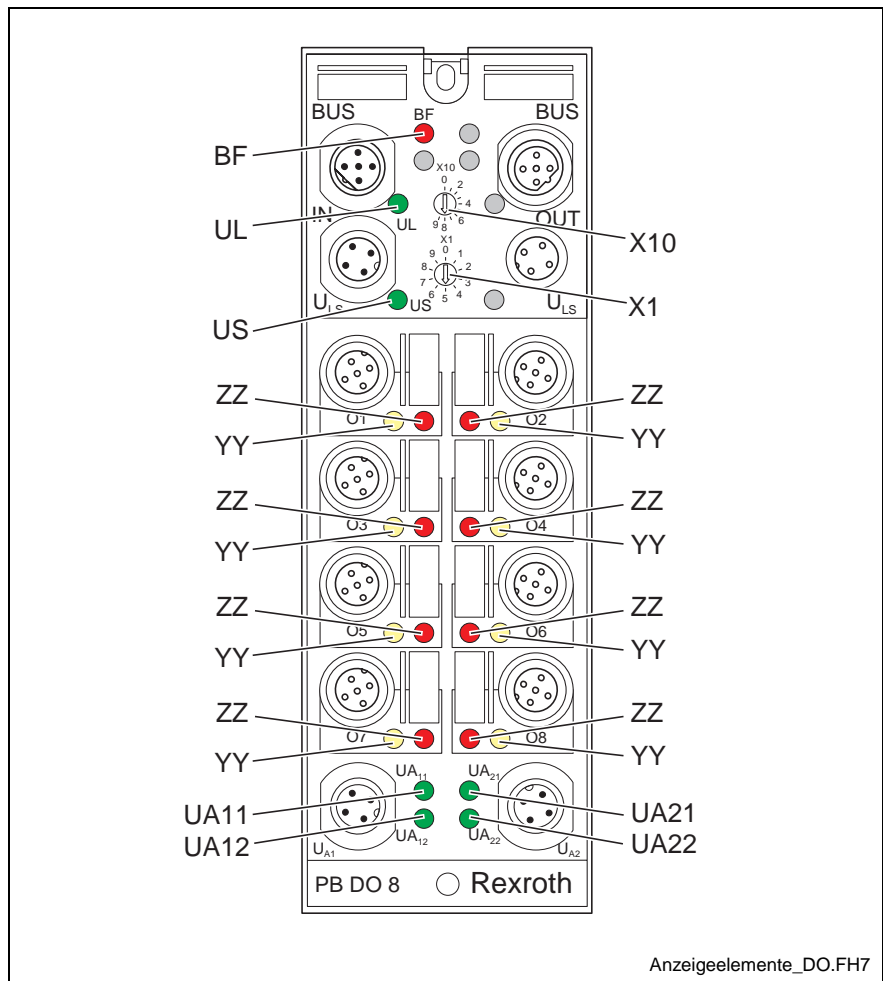

Fig. 6-2: Diagnostic and status indicators

Rotary Encoding Switches

The station address is set using the rotary encoding switches X10 (for the first digit of a two-digit number) and X1 (for the second digit of a two-digit number). The PROFIBUS master addresses the device by means of this station address.

Note: The valid value range is between 1 and 99.
A new address value is only accepted upon device power-up.

Des.	Color	Meaning
BF	Red LED:	Bus failure
	ON:	No cyclic data transmission: <ul style="list-style-type: none"> • PROFIBUS not completed, master not active • Incorrect settings (configuration via master, station address) • Synchronization or parameterization running • Timeout expired
	OFF:	<ul style="list-style-type: none"> • Device is addressed by PROFIBUS and is in the "cyclic process data exchange" state • Missing device supply (In this state the "UL" LED is also OFF because of the missing 24 V communications voltage.)
UL	Green LED:	Communications power
	ON:	Communications power present
	OFF:	Communications power too low
US	Green LED:	Voltage supply
	ON:	Voltage supply present
	OFF:	Voltage supply too low
YY	Yellow LED:	Status indicators of the outputs
	ON:	Output active
	OFF:	Output not active
ZZ	Red LED:	Overload of outputs
	ON:	Output overloaded
	OFF:	Output not overloaded
UA11	Green LED:	Voltage supply for OUT1 and OUT2
	ON:	Voltage supply for OUT1 and OUT2 present
	OFF:	Voltage supply for OUT1 and OUT2 too low
UA12	Green LED:	Voltage supply for OUT3 and OUT4
	ON:	Voltage supply for OUT3 and OUT4 present
	OFF:	Voltage supply for OUT3 and OUT4 too low
UA21	Green LED:	Voltage supply for OUT5 and OUT6
	ON:	Voltage supply for OUT5 and OUT6 present
	OFF:	Voltage supply for OUT5 and OUT6 too low
UA22	Green LED:	Voltage supply for OUT7 and OUT8
	ON:	Voltage supply for OUT7 and OUT8 present
	OFF:	Voltage supply for output OUT7 and OUT8 too low

Fig. 6-3: Local diagnostic and status indicators

6.2 Technical Data

Device Dimensions

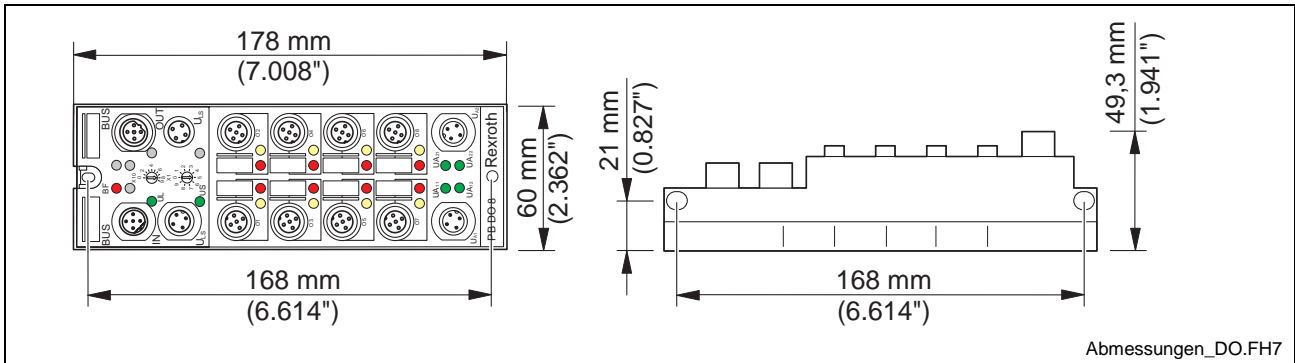

Fig. 6-4: Device Dimensions

General Data

Housing dimensions (width x height x depth)	60 mm x 178 mm x 49.3 mm (2.362 in. x 7.008 in. x 1.941 in.)	
Weight	350 g, approximately	
Operating mode	Process data operation with 8 bits	
Type of actuator connection	2- or 3-wire technology	
Permissible temperature	Operation	-25 °C to +60 °C (-13 °F to +140 °F)
	Storage/transport	-25 °C to +85 °C (-13 °F to +185 °F)
Permissible humidity	Storage/transport	95 %

Note: For a short period, slight condensation may appear on the housing.

Permissible air pressure	Operation	80 kPa to 106 kPa (up to 2000 m [6562 ft.] above sea level)
	Storage/transport	70 kPa to 106 kPa (up to 3000 m [9843 ft.] above sea level)
Degree of protection	IP 65 / IP 67 according to IEC 60529	
Class of protection	Class 3 according to VDE 0106, IEC 60536	

Fig. 6-5: General data

Mechanical Demands

Vibration test sinusoidal vibrations according to EN 60068-2-27	5 g load for each space direction
Shock test according to EN 60068-2-27	30 g load, half sinusoidal wave, positive and negative for each space direction

Fig. 6-6: Mechanical demands

Voltage Supply

Nominal value	24 V DC
Range	18 V DC to 30 V DC
Current consumption I_L at 24 V DC	40 mA, typical (100 mA, maximum)
Current consumption I_S at 24 V DC	3 mA, typical (700 mA, maximum)
Current consumption at U_{AAX} at 24 V DC	12 mA, typical + actuator current (4 A, maximum)

Fig. 6-7: Voltage supply

Digital Outputs

Number	8
Nominal output voltage U_{OUT}	$U_{AAX} - 1 V$
Differential voltage for I_{nom}	$\leq 1 V$
Nominal current I_{nom} per channel	2 A
Total current	16 A (observe derating)
Possible output current during short-circuit	22 A, maximum for 300 μs

Note: Please take this value into account, when selecting the power supply unit.

Protection	Short-circuit; overload
------------	-------------------------

Note: Single chip structure, i.e., all channels are thermally isolated.

Derating with 100 % simultaneity	
Derating with 50 % simultaneity	
Nominal load per channel	<ul style="list-style-type: none"> • Ohmic 48 W • Inductive 48 VA (1.2 H, 12 Ω) • Lamps 48 W

Digital outputs	
Signal delay upon power-up of	
• Ohmic nominal load	Approximately 200 μ s, typical
• Inductive nominal load	Depending on inductive time constant
• Lamp load	Approximately 200 μ s, typical
Signal delay upon power-down of	
• Ohmic nominal load	250 μ s, approximately
• Inductive nominal load	Approximately 150 ms (1.2 H, 12 Ω), depending on inductive time constant
• Nominal lamp load	250 μ s, approximately
Switching frequency with	
• Ohmic nominal load	500 Hz, maximum

Note: This switching frequency is limited by the number of bus devices, the bus structure, the software, and the control or computer system used.

• Inductive nominal load	0.1 Hz, maximum (1.2 H, 12 Ω)
• Nominal lamp load	500 Hz, maximum
Overload response	Auto restart
Restart frequency with ohmic overload (2 Ω)	45 Hz, approximately
Inductive overload response	Output may be damaged
Reverse voltage endurance against short pulses	Protected against reverse voltages
Resistance to permanently applied reverse voltages	No
Response upon power-down	The output follows the supply voltage without delay.
Validity of output data after connecting the voltage supply (power-up)	5 ms, typical
Limitation of the demagnetization voltage induced on circuit interruption	-11 V, approximately
Single maximum energy in free running	1500 W
Protective circuit type	Integrated free-wheeling diode for each channel
Overcurrent shutdown	At 2.6 A, minimum
Output current when switched off	20 μ A, maximum
Output current with ground connection interrupt when switched off	5 mA, maximum

Fig. 6-8: Digital outputs

Error Messages

Overload of outputs	Yes
---------------------	-----

Fig. 6-9: Error messages

Note: If an error is triggered at the outputs due to an overload, the device switches off the corresponding output and sends an error message to the master (see Diagnostic Data on page 6-16).

Output Characteristic Curve When Switched ON (Typical)

Output current (A)	Differential output voltage (V)
0	0
0.20	0.01
0.40	0.03
0.75	0.05
1.00	0.07
1.50	0.12
1.75	0.13
2.00	0.17

Fig. 6-10: Output characteristic curve when switched ON

Output Characteristic Curve When Switched OFF ($U_{AXX} = 30 \text{ V DC}$; Typical)

Load resistance (k Ω)	Output voltage (V)
∞	1.5
1000	0.9
100	0.1
10	0.01
1	0.001

Fig. 6-11: Output characteristic curve when switched OFF

Output Characteristic Curve for Ground Connection Interrupt ($U_{AXX} = 30 \text{ V DC}$; Typical)

Load resistance (k Ω)	Output voltage (V)
∞	29.9
1000	28.8
100	25.0
10	13.6
1	3.8

Fig. 6-12: Output characteristic curve for ground connection interrupt

Interfaces

Interface	
Bus system	PROFIBUS DP

Fig. 6-13: Interface 'Bus system'

Incoming bus	
Coupling of shield connection	Directly to FE
Transmission rate	12 Mbaud, maximum

Fig. 6-14: Interface 'Incoming bus'

Outgoing bus	
Coupling of shield connection	Directly to FE
Transmission rate	2 Mbaud, maximum

Fig. 6-15: Interface 'Outgoing bus'

Note: Because of the integrated series inductance the device can be operated with up to 12 Mbaud without additional external components. A wiring with T-pieces is not supported.

Electrical Isolation/Isolation of the Voltage Areas

Note: For device connection, please note the instructions and regulations in the application description DOK-CONTRL-RF-FLS-PB**-AW...-EN-P.

Separate potentials in the RF FLS PB M12 DO 8 M12-2A output device	
- Test distance	- Test voltage
24 V supply (bus logic) / bus connection	500 V AC, 50 Hz, 1 min
24 V supply (bus logic) / FE	500 V AC, 50 Hz, 1 min
24 V supply (bus logic) / digital outputs (actuator supply)	500 V AC, 50 Hz, 1 min
Bus connection / FE	500 V AC, 50 Hz, 1 min
Bus connection / digital outputs (actuator supply)	500 V AC, 50 Hz, 1 min
FE / digital outputs (actuator supply)	500 V AC, 50 Hz, 1 min

Fig. 6-16: Electrical Isolation/Isolation of the voltage areas

6.3 Connections

Connections of the Device

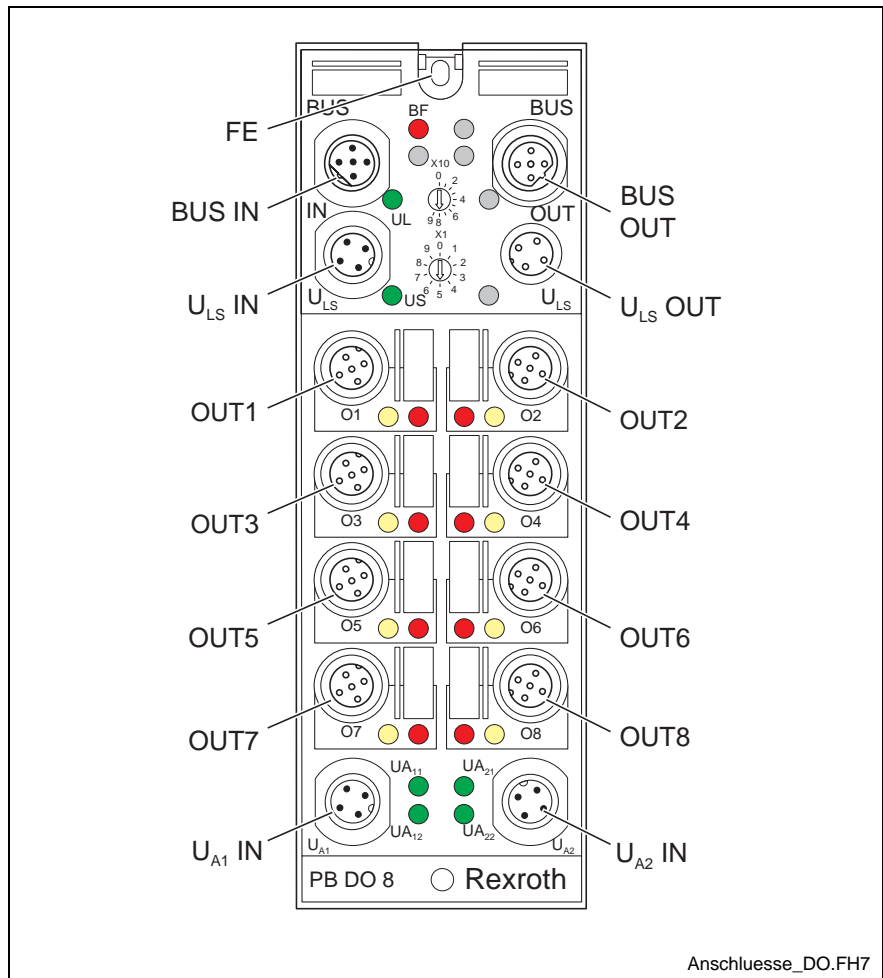

Anschlusse_DO.FH7

Fig. 6-17: Device connections RF-FLS PB M12 DO 8 M12-2A

Pin Assignment

Des.	Meaning
FE	Functional earth ground
BUS IN	PROFIBUS IN
BUS OUT	PROFIBUS OUT
U _{LS} IN	Voltage supply IN (logic and sensor supply)
U _{LS} OUT	Voltage supply OUT (logic and sensor supply) for additional devices
OUT1 to OUT8	Outputs 1 to 8
U _{A1} IN	Voltage supply IN of the outputs (OUT1 to OUT4) with voltages U _{A11} and U _{A12}
U _{A2} IN	Voltage supply IN of outputs (OUT5 to OUT8) with voltages U _{A21} and U _{A22}

Fig. 6-18: Pin assignment

PROFIBUS Pin Assignment

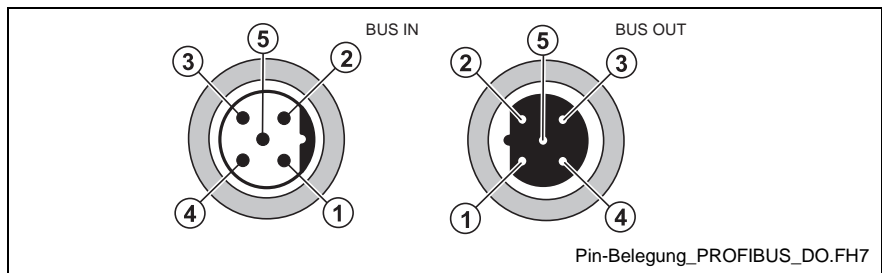

Fig. 6-19: PROFIBUS pin assignment (encoded according to M12 B)

Pin	IN	OUT
1	VP	VP
2	RxD/TxD-N (A)	RxD/TxD-N (A)
3	DGND	DGND
4	RxD/TxD-P (B)	RxD/TxD-P (B)
5	Shield	Shield

Fig. 6-20: PROFIBUS pin assignment (encoded according to M12 B)

Note: The thread is used for additional shielding.

Pin Assignment of the Voltage Supply U_{LS}

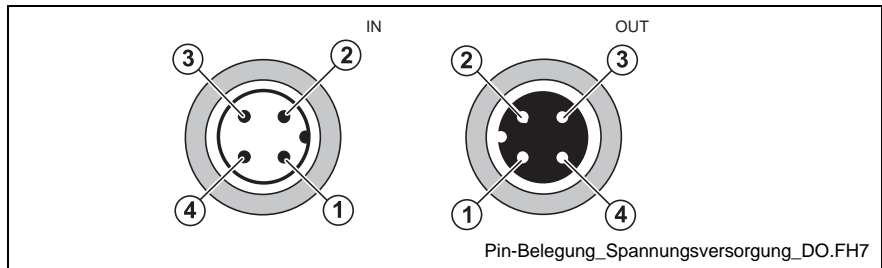

Fig. 6-21: Pin assignment of the voltage supply U_{LS}

Pin	IN	OUT
1	$U_L +24\text{ V}$	$U_L +24\text{ V}$
2	$U_S\text{ GND}$	$U_S\text{ GND}$
3	$U_L\text{ GND}$	$U_L\text{ GND}$
4	$U_S +24\text{ V}$	$U_S +24\text{ V}$

Fig. 6-22: Pin assignment of the voltage supply U_{LS}

Pin Assignment of the Voltage Supply U_A of the Outputs

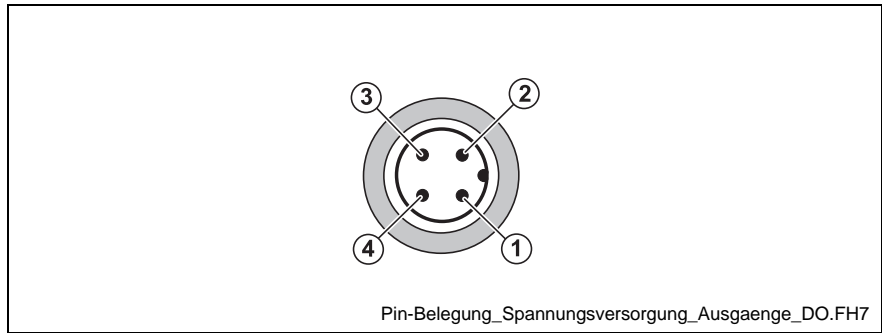

Fig. 6-23: Pin assignment of the voltage supply U_A of the outputs

Pin	U_{A1} IN	U_{A2} IN
1	U_{A11} +24 V	U_{A21} +24 V
2	U_{A12} GND	U_{A22} GND
3	U_{A11} GND	U_{A21} GND
4	U_{A12} +24 V	U_{A22} +24 V

Fig. 6-24: Pin assignment of the voltage supply U_A of the outputs

Pin Assignment of the Outputs

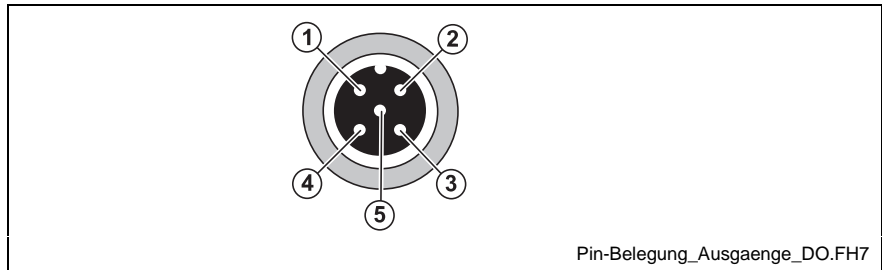

Fig. 6-25: Pin assignment of the outputs

Pin	Output sockets
1	Not used
2	Not used
3	GND
4	Output
5	FE

Fig. 6-26: Pin assignment of the outputs

Internal Circuit Diagram

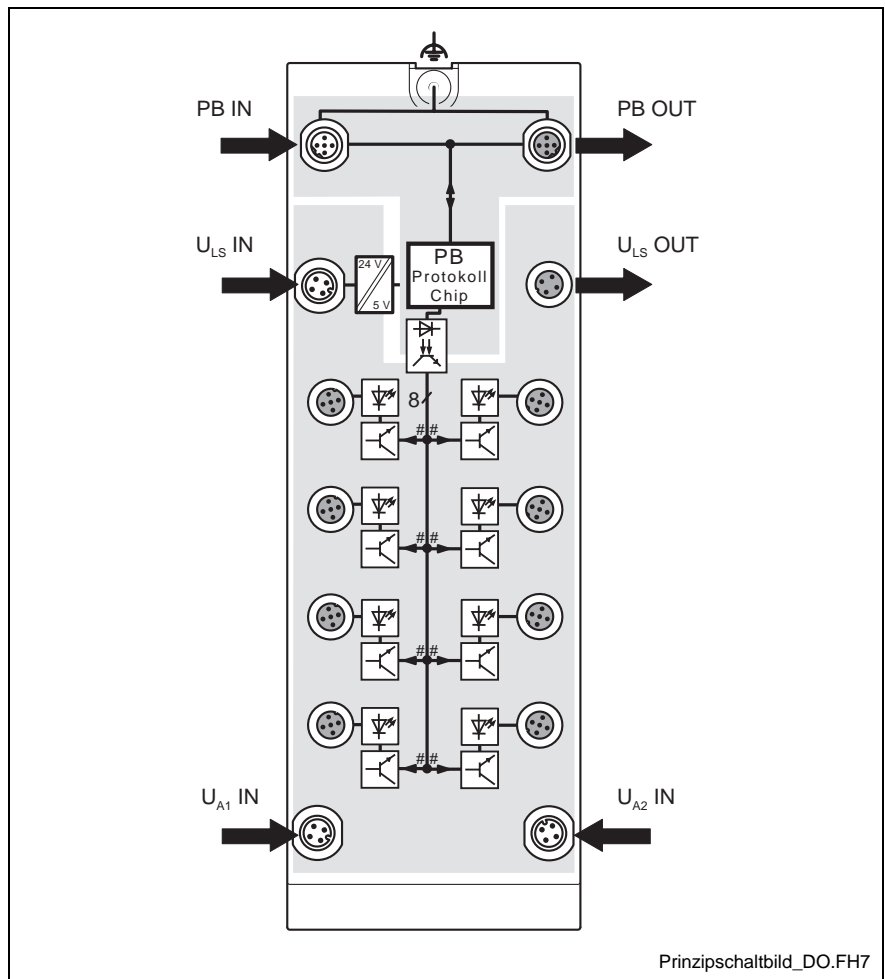

Fig. 6-27: Internal wiring of the connection points

Key







Symbol	Meaning
	Functional earth ground
	Isolating transformer
	PROFIBUS protocol chip (bus logic including voltage conditioning)
	Optocoupler
	LED
	Transistor
	Output
	Electrically isolated area (for this, see also section Electrical Isolation/Isolation of the Voltage Areas on page 6-8)

Fig. 6-28: Key

Connection Example

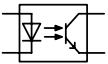
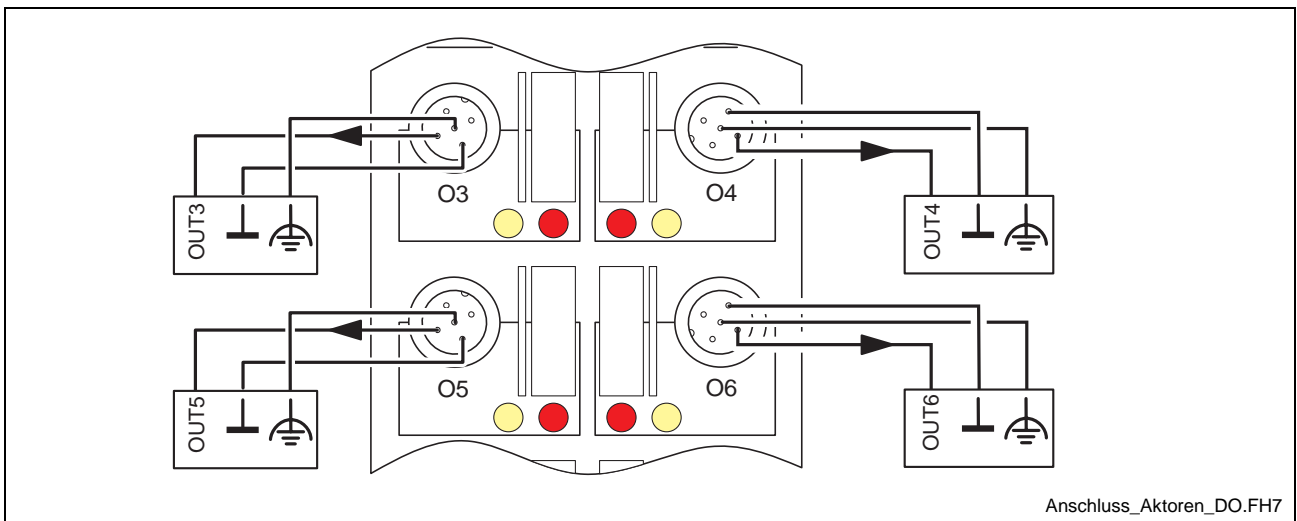

Fig. 6-29: Actuator connection example

Connection Notes

Note: Meet noise immunity requirements

Connect FE using a mounting screw or a cable connection to the FE connection link (when mounting on the side or on a non-conductive surface).

Note: Ensure degree of IP protection

To ensure IP 65 / IP 67 protection, cover unused sockets with protective caps.

Note: Avoid polarity reversal

Avoid polarity reversal of the supply voltages U_L , U_S and U_A to avoid damage to the device.

Note: Observe connection point assignment

When connecting the actuators, observe the assignment of the connection points to the PROFIBUS output data (see Process Data on page 6-15).

Configuration Data

ID number	066C _{hex}
Output address area	8 bits

Fig. 6-30: Configuration data

Process Data

Assignment of the connection points to the OUT process data

(Byte.Bit) view	Byte	Byte 0							
	Bit	7	6	5	4	3	2	1	0
Device	Output	8	7	6	5	4	3	2	1

Fig. 6-31: OUT process data

Diagnostic Data

Mapping of the diagnostic data in PROFIBUS

Diagnostic data	Bit 7	Bit 6	Bit 5	Bit 4	Bit 3	Bit 2	Bit 1	Bit 0	Remark
Byte 0	X	X	X	X	X	X	X	X	Station status 1
Byte 1	X	X	X	X	X	X	X	X	Station status 2
Byte 2	X	X	X	X	X	X	X	X	Station status 3
Byte 3	X	X	X	X	X	X	X	X	Master address diagnostics
Byte 4	0	0	0	0	0	1	1	0	High ID number
Byte 5	0	1	1	0	1	1	0	0	Low ID number
Byte 6	0	0	0	0	0	1	1	1	Diagnostic header
Byte 7	M.7	M.6	M.5	M.4	M.3	M.2	M.1	M.0	Device diagnostics
Byte 8	0	0	0	0	0	0	0	0	Reserved
Byte 9	0	0	0	0	0	0	0	0	Reserved
Byte 10	0	0	0	0	0	0	0	0	Reserved
Byte 11	0	0	0	0	0	0	0	0	Reserved
Byte 12	X	X	0	0	0	0	0	0	Reserved

Fig. 6-32: Diagnostic data

Note: Bytes 0 to 6 are PROFIBUS standard. Bytes 7 to 12 are device-specific.

Diagnostic data for device diagnostic

Bit	Remark	Assignment
M.0-M.4	Reserved	0
M.5	Overload status of the outputs	OUT1 to OUT8
M.6	Status of the U _L device supply	1, if device supply too low
M.7	Reserved	0

Fig. 6-33: Diagnostic data for device diagnostic

Note: If a diagnostic event occurs, the diagnostic data is sent to the master by means of a diagnostic telegram generated once by the device.

The current diagnostic data status can be read by the device at any time.

7 Ordering Information

7.1 RECO Fieldline PROFIBUS Devices

Description	Short text	Material no.
Stand alone device for PROFIBUS with 8 digital inputs	RF-FLS PB M12 DI 8 M12	294587
Stand alone device for PROFIBUS with 4 digital inputs and 4 digital outputs	RF-FLS PB M12 DIO 4/4 M12-2A	294586
Stand alone device for PROFIBUS with 8 digital outputs	RF-FLS PB M12 DO 8 M12-2A	294585

Fig. 7-1: Ordering information 'PROFIBUS devices'

7.2 RECO Fieldline PROFIBUS Bus Cables

Description	Length	Short text	Material no.
Male connector, straight, shielded, M12 B-encoded, 5 pins, open end	10,0 m	IKB0048/010,0	296612
Female connector, straight, shielded, M12 B-encoded, 5 pins, open end	10,0 m	IKB0049/010,0	296613
Male connector, straight, shielded, M12 B-encoded; Female connector, straight, shielded, M12 B-encoded, 5 pins	0,5 m	IKB0050/000,5	296614
	2,0 m	IKB0050/002,0	296615
	5,0 m	IKB0050/005,0	296616
	10,0 m	IKB0050/010,0	296617

Fig. 7-2: Ordering information 'PROFIBUS bus cables'

7.3 RECO Fieldline Voltage Cables

Description	Length	Short text	Material no.
Female connector, straight, unshielded, M12 A-encoded, 4 pins, open end	0,5 m	IKL0267/005,0	296585
	10,0 m	IKL0267/010,0	296624
	15,0 m	IKL0267/015,0	296625
Male connector, straight, unshielded, M12 A-encoded; Female connector, straight, unshielded, M12 A-encoded, 4 pins	0,5 m	IKL0268/000,5	296626
	2,0 m	IKL0268/002,0	296627
	5,0 m	IKL0268/005,0	296628
	10,0 m	IKL0268/010,0	296629

Fig. 7-3: Ordering information 'Voltage cables'

7.4 RECO Fieldline PROFIBUS Accessories

Description	Short text	Material no.
Terminating resistor PROFIBUS	INS0762/CNN	296632

Fig. 7-4: Ordering information 'PROFIBUS accessories'

7.5 Further Documentation

Description	Short text	Material no.
RECO Fieldline PROFIBUS, Application Description	DOK-CONTRL-RF-FLS-PB**-AW..-EN-P	298520

Fig. 7-5: Further documentation

8 List of Figures

- Fig. 1-1: PROFIBUS devices 1-1
- Fig. 3-1: Hazard classification (according to ANSI Z535) 3-1
- Fig. 4-1: RECO Fieldline device RF-FLS PB M12 DI 8 M12 4-1
- Fig. 4-2: Diagnostic and status indicators 4-2
- Fig. 4-3: Local diagnostic and status indicators 4-3
- Fig. 4-4: Device dimensions 4-4
- Fig. 4-5: General data 4-4
- Fig. 4-6: Mechanical demands 4-4
- Fig. 4-7: Voltage supply 4-5
- Fig. 4-8: Digital inputs 4-5
- Fig. 4-9: Input characteristic curve 4-5
- Fig. 4-10: Sensor supply 4-6
- Fig. 4-11: Error messages to the higher level control or computer system 4-6
- Fig. 4-12: Interface 'Bus system' 4-6
- Fig. 4-13: Interface 'Incoming bus' 4-6
- Fig. 4-14: Interface 'Outgoing bus' 4-6
- Fig. 4-15: Electrical isolation/Isolation of the voltage areas 4-7
- Fig. 4-16: Connections of the device 4-7
- Fig. 4-17: Pin assignment 4-8
- Fig. 4-18: PROFIBUS pin assignment (encoded according to M12 B) 4-8
- Fig. 4-19: PROFIBUS pin assignment (encoded according to M12 B) 4-8
- Fig. 4-20: Pin assignment of the voltage supply U_{LS} 4-9
- Fig. 4-21: Pin assignment of the voltage supply U_{LS} 4-9
- Fig. 4-22: Pin assignment of the inputs 4-9
- Fig. 4-23: Pin assignment of the inputs 4-9
- Fig. 4-24: Assignment of the input sockets 4-10
- Fig. 4-25: Internal wiring of the connection points 4-11
- Fig. 4-26: Key 4-11
- Fig. 4-27: Sensor connection example 4-12
- Fig. 4-28: Configuration data 4-13
- Fig. 4-29: IN process data 4-13
- Fig. 4-30: Diagnostic data 4-14
- Fig. 4-31: Diagnostic data for device diagnostic 4-14
- Fig. 5-1: RECO Fieldline device RF-FLS PB M12 DIO 4/4 M12-2A 5-1
- Fig. 5-2: Diagnostic and status indicators 5-2
- Fig. 5-3: Local diagnostic and status indicators 5-3
- Fig. 5-4: Device dimensions 5-4
- Fig. 5-5: General data 5-4
- Fig. 5-6: Mechanical demands 5-4
- Fig. 5-7: Voltage supply 5-5
- Fig. 5-8: Digital inputs 5-5

- Fig. 5-9: Input characteristic curve 5-5
- Fig. 5-10: Sensor supply 5-6
- Fig. 5-11: Error messages to the higher-level control or computer system 5-6
- Fig. 5-12: Digital outputs 5-7
- Fig. 5-13: Error messages 5-8
- Fig. 5-14: Output characteristic curve when switched ON 5-8
- Fig. 5-15: Output characteristic curve when switched OFF 5-8
- Fig. 5-16: Output characteristic curve for ground connection interrupt 5-8
- Fig. 5-17: Interface 'Bus system' 5-9
- Fig. 5-18: Interface 'Incoming bus' 5-9
- Fig. 5-19: Interface 'Outgoing bus' 5-9
- Fig. 5-20: Electrical isolation/Isolation of the voltage areas 5-9
- Fig. 5-21: Device connections RF-FLS PB M12 DIO 4/4 M12-2A 5-10
- Fig. 5-22: Pin assignment 5-10
- Fig. 5-23: PROFIBUS pin assignment (encoded according to M12 B) 5-11
- Fig. 5-24: PROFIBUS pin assignment (encoded according to M12 B) 5-11
- Fig. 5-25: Pin assignment of the voltage supply U_{LS} 5-11
- Fig. 5-26: Pin assignment of the voltage supply U_{LS} 5-11
- Fig. 5-27: Pin assignment of the voltage supply U_A of the outputs 5-12
- Fig. 5-28: Pin assignment of the voltage supply U_A of the outputs 5-12
- Fig. 5-29: Pin assignment of the inputs and outputs 5-12
- Fig. 5-30: Pin assignment of the inputs and outputs 5-12
- Fig. 5-31: Assignment of the input sockets 5-13
- Fig. 5-32: Internal wiring of the connection points 5-14
- Fig. 5-33: Key 5-15
- Fig. 5-34: Sensor and actuator connection example 5-16
- Fig. 5-35: Configuration data 5-17
- Fig. 5-36: IN process data 5-17
- Fig. 5-37: OUT process data 5-17
- Fig. 5-38: Diagnostic data 5-18
- Fig. 5-39: Diagnostic data for device diagnostics 5-19
- Fig. 6-1: RECO Fieldline device RF-FLS PB M12 DO 8 M12-2A 6-1
- Fig. 6-2: Diagnostic and status indicators 6-2
- Fig. 6-3: Local diagnostic and status indicators 6-3
- Fig. 6-4: Device Dimensions 6-4
- Fig. 6-5: General data 6-4
- Fig. 6-6: Mechanical demands 6-4
- Fig. 6-7: Voltage supply 6-5
- Fig. 6-8: Digital outputs 6-6
- Fig. 6-9: Error messages 6-6
- Fig. 6-10: Output characteristic curve when switched ON 6-7
- Fig. 6-11: Output characteristic curve when switched OFF 6-7
- Fig. 6-12: Output characteristic curve for ground connection interrupt 6-7

- Fig. 6-13: Interface 'Bus system' 6-8
- Fig. 6-14: Interface 'Incoming bus' 6-8
- Fig. 6-15: Interface 'Outgoing bus' 6-8
- Fig. 6-16: Electrical Isolation/Isolation of the voltage areas 6-8
- Fig. 6-17: Device connections RF-FLS PB M12 DO 8 M12-2A 6-9
- Fig. 6-18: Pin assignment 6-9
- Fig. 6-19: PROFIBUS pin assignment (encoded according to M12 B) 6-10
- Fig. 6-20: PROFIBUS pin assignment (encoded according to M12 B) 6-10
- Fig. 6-21: Pin assignment of the voltage supply U_{LS} 6-10
- Fig. 6-22: Pin assignment of the voltage supply U_{LS} 6-10
- Fig. 6-23: Pin assignment of the voltage supply U_A of the outputs 6-11
- Fig. 6-24: Pin assignment of the voltage supply U_A of the outputs 6-11
- Fig. 6-25: Pin assignment of the outputs 6-11
- Fig. 6-26: Pin assignment of the outputs 6-11
- Fig. 6-27: Internal wiring of the connection points 6-12
- Fig. 6-28: Key 6-13
- Fig. 6-29: Actuator connection example 6-14
- Fig. 6-30: Configuration data 6-15
- Fig. 6-31: OUT process data 6-15
- Fig. 6-32: Diagnostic data 6-16
- Fig. 6-33: Diagnostic data for device diagnostic 6-16
- Fig. 7-1: Ordering information 'PROFIBUS devices' 7-1
- Fig. 7-2: Ordering information 'PROFIBUS bus cables' 7-1
- Fig. 7-3: Ordering information 'Voltage cables' 7-1
- Fig. 7-4: Ordering information 'PROFIBUS accessories' 7-1
- Fig. 7-5: Further documentation 7-2

9 Service & Support

9.1 Helpdesk

Unser Kundendienst-Helpdesk im Hauptwerk Lohr am Main steht Ihnen mit Rat und Tat zur Seite. Sie erreichen uns

- telefonisch - by phone:
über Service Call Entry Center
- via Service Call Entry Center

- per Fax - by fax:

- per e-Mail - by e-mail: service.svc@boschrexroth.de

Our service helpdesk at our headquarters in Lohr am Main, Germany can assist you in all kinds of inquiries. Contact us

49 (0) 9352 40 50 60

Mo-Fr 07:00-18:00
Mo-Fr 7:00 am - 6:00 pm

+49 (0) 9352 40 49 41

9.2 Service-Hotline

Außerhalb der Helpdesk-Zeiten ist der Service direkt ansprechbar unter

After helpdesk hours, contact our service department directly at

+49 (0) 171 333 88 26

oder - or

+49 (0) 172 660 04 06

9.3 Internet

Unter www.boschrexroth.com finden Sie ergänzende Hinweise zu Service, Reparatur und Training sowie die **aktuellen** Adressen *) unserer auf den folgenden Seiten aufgeführten Vertriebs- und Servicebüros.



Verkaufsniederlassungen



Niederlassungen mit Kundendienst

Außerhalb Deutschlands nehmen Sie bitte zuerst Kontakt mit unserem für Sie nächstgelegenen Ansprechpartner auf.

*) Die Angaben in der vorliegenden Dokumentation können seit Drucklegung überholt sein.

At www.boschrexroth.com you may find additional notes about service, repairs and training in the Internet, as well as the **actual** addresses *) of our sales- and service facilities figuring on the following pages.



sales agencies



offices providing service

Please contact our sales / service office in your area first.

*) Data in the present documentation may have become obsolete since printing.

9.4 Vor der Kontaktaufnahme... - Before contacting us...

Wir können Ihnen schnell und effizient helfen wenn Sie folgende Informationen bereithalten:

1. detaillierte Beschreibung der Störung und der Umstände.
2. Angaben auf dem Typenschild der betreffenden Produkte, insbesondere Typenschlüssel und Seriennummern.
3. Tel./Faxnummern und e-Mail-Adresse, unter denen Sie für Rückfragen zu erreichen sind.

For quick and efficient help, please have the following information ready:

1. Detailed description of the failure and circumstances.
2. Information on the type plate of the affected products, especially type codes and serial numbers.
3. Your phone/fax numbers and e-mail address, so we can contact you in case of questions.

9.5 Kundenbetreuungsstellen - Sales & Service Facilities

Deutschland – Germany

vom Ausland:

(0) nach Landeskennziffer weglassen!

from abroad:

don't dial (0) after country code!

Vertriebsgebiet Mitte Germany Centre Bosch Rexroth AG Bgm.-Dr.-Nebel-Str. 2 / Postf. 1357 97816 Lohr am Main / 97803 Lohr Kompetenz-Zentrum Europa Tel.: +49 (0)9352 40-0 Fax: +49 (0)9352 40-4885	SERVICE CALL ENTRY CENTER MO – FR von 07:00 - 18:00 Uhr from 7 am – 6 pm Tel. +49 (0) 9352 40 50 60 service.svc@boschrexroth.de	SERVICE HOTLINE MO – FR von 17:00 - 07:00 Uhr from 5 pm - 7 am + SA / SO Tel.: +49 (0)172 660 04 06 oder / or Tel.: +49 (0)171 333 88 26	SERVICE ERSATZTEILE / SPARES verlängerte Ansprechzeit - extended office time - ♦ nur an Werktagen - only on working days - ♦ von 07:00 - 18:00 Uhr - from 7 am - 6 pm - Tel. +49 (0) 9352 40 42 22
Vertriebsgebiet Süd Germany South Bosch Rexroth AG Landshuter Allee 8-10 80637 München Tel.: +49 (0)89 127 14-0 Fax: +49 (0)89 127 14-490	Vertriebsgebiet West Germany West Bosch Rexroth AG Regionalzentrum West Borsigstrasse 15 40880 Ratingen Tel.: +49 (0)2102 409-0 Fax: +49 (0)2102 409-406 +49 (0)2102 409-430	Gebiet Südwest Germany South-West Bosch Rexroth AG Service-Regionalzentrum Süd-West Siemensstr.1 70736 Fellbach Tel.: +49 (0)711 51046-0 Fax: +49 (0)711 51046-248	
Vertriebsgebiet Nord Germany North Bosch Rexroth AG Walsroder Str. 93 30853 Langenhagen Tel.: +49 (0) 511 72 66 57-0 Service: +49 (0) 511 72 66 57-256 Fax: +49 (0) 511 72 66 57-93 Service: +49 (0) 511 72 66 57-95	Vertriebsgebiet Mitte Germany Centre Bosch Rexroth AG Regionalzentrum Mitte Waldecker Straße 13 64546 Mörfelden-Walldorf Tel.: +49 (0) 61 05 702-3 Fax: +49 (0) 61 05 702-444	Vertriebsgebiet Ost Germany East Bosch Rexroth AG Beckerstraße 31 09120 Chemnitz Tel.: +49 (0)371 35 55-0 Fax: +49 (0)371 35 55-333	Vertriebsgebiet Ost Germany East Bosch Rexroth AG Regionalzentrum Ost Walter-Köhn-Str. 4d 04356 Leipzig Tel.: +49 (0)341 25 61-0 Fax: +49 (0)341 25 61-111

Europa (West) - Europe (West)

vom Ausland: (0) nach Landeskennziffer weglassen, **Italien:** 0 nach Landeskennziffer mitwählen
from abroad: don't dial (0) after country code, **Italy:** dial 0 after country code

Austria - Österreich Bosch Rexroth GmbH Electric Drives & Controls Tel.: +43 (0)1 985 25 40 Fax: +43 (0)1 985 25 40-93	Austria – Österreich Bosch Rexroth GmbH Electric Drives & Controls Industriepark 18 4061 Pasching Tel.: +43 (0)7221 605-0 Fax: +43 (0)7221 605-21	Belgium - Belgien Bosch Rexroth AG Electric Drives & Controls Industrielaan 8 1740 Ternat Tel.: +32 (0)2 5830719 - service: +32 (0)2 5830717 Fax: +32 (0)2 5830731 service@boschrexroth.be	Denmark - Dänemark BEC A/S Zinkvej 6 8900 Randers Tel.: +45 (0)87 11 90 60 Fax: +45 (0)87 11 90 61
Great Britain – Großbritannien Bosch Rexroth Ltd. Electric Drives & Controls Broadway Lane, South Cerney Cirencester, Glos GL7 5UH Tel.: +44 (0)1285 863000 Fax: +44 (0)1285 863030 sales@boschrexroth.co.uk service@boschrexroth.co.uk	Finland - Finnland Bosch Rexroth Oy Electric Drives & Controls Ansatie 6 017 40 Vantaa Tel.: +358 (0)9 84 91-11 Fax: +358 (0)9 84 91-13 60	France - Frankreich Bosch Rexroth SAS Electric Drives & Controls Avenue de la Trentaine (BP. 74) 77503 Chelles Cedex Tel.: +33 (0)164 72-70 00 Fax: +33 (0)164 72-63 00 Hotline: +33 (0)608 33 43 28	France - Frankreich Bosch Rexroth SAS Electric Drives & Controls ZI de Thibaud, 20 bd. Thibaud (BP. 1751) 31084 Toulouse Tel.: +33 (0)5 61 43 61 87 Fax: +33 (0)5 61 43 94 12
France – Frankreich Bosch Rexroth SAS Electric Drives & Controls 91, Bd. Irène Joliot-Curie 69634 Vénissieux – Cedex Tel.: +33 (0)4 78 78 53 65 Fax: +33 (0)4 78 78 53 62	Italy - Italien Bosch Rexroth S.p.A. Via G. Di Vittoria, 1 20063 Cernusco S/N.MI Tel.: +39 02 92 365 1 +39 02 92 365 326 Fax: +39 02 92 365 500 +39 02 92 365 516378	Italy - Italien Bosch Rexroth S.p.A. Via Paolo Veronesi, 250 10148 Torino Tel.: +39 011 224 88 11 Fax: +39 011 224 88 30	Italy - Italien Bosch Rexroth S.p.A. Via del Progresso, 16 (Zona Ind.) 35020 Padova Tel.: +39 049 8 70 13 70 Fax: +39 049 8 70 13 77
Italy - Italien Bosch Rexroth S.p.A. Via Mascia, 1 80053 Castellammare di Stabia NA Tel.: +39 081 8 71 57 00 Fax: +39 081 8 71 68 85	Italy - Italien Bosch Rexroth S.p.A. Viale Oriani, 38/A 40137 Bologna Tel.: +39 051 34 14 14 Fax: +39 051 34 14 22	Netherlands – Niederlande/Holland Bosch Rexroth B.V. Kruisbroeksestraat 1 (P.O. Box 32) 5281 RV Boxtel Tel.: +31 (0)411 65 19 51 Fax: +31 (0)411 65 14 83 www.boschrexroth.nl	Netherlands - Niederlande/Holland Bosch Rexroth Services B.V. Technical Services Kruisbroeksestraat 1 (P.O. Box 32) 5281 RV Boxtel Tel.: +31 (0)411 65 19 51 Fax: +31 (0)411 67 78 14 services@boschrexroth.nl
Norway - Norwegen Bosch Rexroth AS Electric Drives & Controls Berghagan 1 or: Box 3007 1405 Ski-Langhus 1402 Ski Tel.: +47 (0)64 86 41 00 Fax: +47 (0)64 86 90 62 jul.ruud@rexroth.no	Spain - Spanien Bosch Rexroth S.A. Electric Drives & Controls Centro Industrial Santiga Obradors s/n 08130 Santa Perpetua de Mogoda Barcelona Tel.: +34 9 37 47 94 00 Fax: +34 9 37 47 94 01	Spain – Spanien Goimendi S.A. Electric Drives & Controls Parque Empresarial Zuatzu C/ Francisco Grandmontagne no.2 20018 San Sebastian Tel.: +34 9 43 31 84 21 - service: +34 9 43 31 84 56 Fax: +34 9 43 31 84 27 - service: +34 9 43 31 84 60 sat.indramat@goimendi.es	Sweden - Schweden Rexroth Mecman Svenska AB Electric Drives & Controls - Varuvägen 7 (Service: Konsumentvägen 4, Älfsjö) 125 81 Stockholm Tel.: +46 (0)8 727 92 00 Fax: +46 (0)8 647 32 77
Sweden - Schweden Rexroth Mecman Svenska AB Electric Drives & Controls Ekvändan 7 254 67 Helsingborg Tel.: +46 (0) 42 38 88 -50 Fax: +46 (0) 42 38 88 -74	Switzerland West - Schweiz West Bosch Rexroth Suisse SA Electric Drives & Controls Rue du village 1 1020 Renens Tel.: +41 (0)21 632 84 20 Fax: +41 (0)21 632 84 21	Switzerland East - Schweiz Ost Bosch Rexroth Schweiz AG Electric Drives & Controls Hemrietstrasse 2 8863 Buttikon Tel. +41 (0) 55 46 46 111 Fax +41 (0) 55 46 46 222	

Europa (Ost) - Europe (East)

vom Ausland: (0) nach Landeskenziffer weglassen
from abroad: don't dial (0) after country code

<p>Czech Republic - Tschechien</p> <p>Bosch -Rexroth, spol.s.r.o. Hviezdoslavova 5 627 00 Brno Tel.: +420 (0)5 48 126 358 Fax: +420 (0)5 48 126 112</p>	<p>Czech Republic - Tschechien</p> <p>DEL a.s. Strojirenská 38 591 01 Zdar nad Sázavou Tel.: +420 566 64 3144 Fax: +420 566 62 1657</p>	<p>Hungary - Ungarn</p> <p>Bosch Rexroth Kft. Angol utca 34 1149 Budapest Tel.: +36 (1) 422 3200 Fax: +36 (1) 422 3201</p>	<p>Poland – Polen</p> <p>Bosch Rexroth Sp.zo.o. ul. Staszica 1 05-800 Pruszków Tel.: +48 22 738 18 00 – service: +48 22 738 18 46 Fax: +48 22 758 87 35 – service: +48 22 738 18 42</p>
<p>Poland – Polen</p> <p>Bosch Rexroth Sp.zo.o. Biuro Poznan ul. Dabrowskiego 81/85 60-529 Poznan Tel.: +48 061 847 64 62 /-63 Fax: +48 061 847 64 02</p>	<p>Romania - Rumänien</p> <p>East Electric S.R.L. B-dul Basarabie, nr.250, sector 3 73429 Bucuresti Tel./Fax: +40 (0)21 255 35 07 +40 (0)21 255 77 13 Fax: +40 (0)21 725 61 21 est@mb.roknet.ro</p>	<p>Romania - Rumänien</p> <p>Bosch Rexroth Sp.zo.o. Str. Drobety nr. 4-10, app. 14 70258 Bucuresti, Sector 2 Tel.: +40 (0)1 210 48 25 +40 (0)1 210 29 50 Fax: +40 (0)1 210 29 52</p>	<p>Russia - Russland</p> <p>Bosch Rexroth OOO Wjatskaja ul. 27/15 127015 Moskau Tel.: +7-095-785 74 78 +7-095 785 74 79 Fax: +7 095 785 74 77 laura.kanina@boschrexroth.ru</p>
<p>Russia - Russland</p> <p>ELMIS 10, Internationalnaya 246640 Gomel, Belarus Tel.: +375/ 232 53 42 70 +375/ 232 53 21 69 Fax: +375/ 232 53 37 69 elmis_ltd@yahoo.com</p>	<p>Turkey - Türkei</p> <p>Bosch Rexroth Otomasyon San & Tic. A..S. Fevzi Cakmak Cad No. 3 34630 Sefaköy Istanbul Tel.: +90 212 541 60 70 Fax: +90 212 599 34 07</p>	<p>Slowenia - Slowenien</p> <p>DOMEL Otoki 21 64 228 Zelezniki Tel.: +386 5 5117 152 Fax: +386 5 5117 225 brane.ozebek@domel.si</p>	

Africa, Asia, Australia – incl. Pacific Rim

<p>Australia - Australien</p> <p>AIMS - Australian Industrial Machinery Services Pty. Ltd. 28 Westside Drive Laverton North Vic 3026 Melbourne</p> <p>Tel.: +61 3 93 243 321 Fax: +61 3 93 243 329 Hotline: +61 4 19 369 195 terryobrien@aimservices.com.au</p>	<p>Australia - Australien</p> <p>Bosch Rexroth Pty. Ltd. No. 7, Endeavour Way Braeside Victoria, 31 95 Melbourne</p> <p>Tel.: +61 3 95 80 39 33 Fax: +61 3 95 80 17 33 mel@rexroth.com.au</p>	<p>China</p> <p>Shanghai Bosch Rexroth Hydraulics & Automation Ltd. Waigaoqiao, Free Trade Zone No.122, Fu Te Dong Yi Road Shanghai 200131 - P.R.China</p> <p>Tel.: +86 21 58 66 30 30 Fax: +86 21 58 66 55 23 richard.yang_sh@boschrexroth.com.cn gf.zhu_sh@boschrexroth.com.cn</p>	<p>China</p> <p>Shanghai Bosch Rexroth Hydraulics & Automation Ltd. 4/f, Marine Tower No.1, Pudong Avenue Shanghai 200120 - P.R.China</p> <p>Tel.: +86 21 68 86 15 88 Fax: +86 21 58 40 65 77</p>
<p>China</p> <p>Bosch Rexroth China Ltd. 15/F China World Trade Center 1, Jianguomenwai Avenue Beijing 100004, P.R.China</p> <p>Tel.: +86 10 65 05 03 80 Fax: +86 10 65 05 03 79</p>	<p>China</p> <p>Bosch Rexroth China Ltd. Guangzhou Repres. Office Room 1014-1016, Metro Plaza, Tian He District, 183 Tian He Bei Rd Guangzhou 510075, P.R.China</p> <p>Tel.: +86 20 8755-0030 +86 20 8755-0011 Fax: +86 20 8755-2387</p>	<p>China</p> <p>Bosch Rexroth (China) Ltd. A-5F., 123 Lian Shan Street Sha He Kou District Dalian 116 023, P.R.China</p> <p>Tel.: +86 411 46 78 930 Fax: +86 411 46 78 932</p>	<p>China</p> <p>Melchers GmbH BRC-SE, Tightening & Press-fit 13 Floor Est Ocean Centre No.588 Yanan Rd. East 65 Yanan Rd. West Shanghai 200001</p> <p>Tel.: +86 21 6352 8848 Fax: +86 21 6351 3138</p>
<p>Hongkong</p> <p>Bosch Rexroth (China) Ltd. 6th Floor, Yeung Yiu Chung No.6 Ind Bldg. 19 Cheung Shun Street Cheung Sha Wan, Kowloon, Hongkong</p> <p>Tel.: +852 22 62 51 00 Fax: +852 27 41 33 44 alexis.siu@boschrexroth.com.hk</p>	<p>India - Indien</p> <p>Bosch Rexroth (India) Ltd. Electric Drives & Controls Plot. A-58, TTC Industrial Area Thane Turbhe Midc Road Mahape Village Navi Mumbai - 400 701</p> <p>Tel.: +91 22 7 61 46 22 Fax: +91 22 7 68 15 31</p>	<p>India - Indien</p> <p>Bosch Rexroth (India) Ltd. Electric Drives & Controls Plot. 96, Phase III Peenya Industrial Area Bangalore – 560058</p> <p>Tel.: +91 80 41 17 02 -11...-18 Fax: +91 80 83 94 345 +91 80 83 97 374 mohanvelu.t@boschrexroth.co.in</p>	<p>India - Indien</p> <p>Bosch Rexroth (India) Ltd. 1st Floor, S-10 Green Park ext. Market New Delhi – 110016</p> <p>Tel.: +91 1 16 56 68 88 Fax: +91 1 16 56 68 87</p>
<p>Indonesia - Indonesien</p> <p>PT. Bosch Rexroth Building # 202, Cilandak Commercial Estate Jl. Cilandak KKO, Jakarta 12560</p> <p>Tel.: +62 21 7891169 (5 lines) Fax: +62 21 7891170 - 71</p>	<p>Japan</p> <p>Bosch Rexroth Automation Corp. Service Center Japan Yutakagaoka 1810, Meito-ku, NAGOYA 465-0035, Japan</p> <p>Tel.: +81 52 777 88 41 +81 52 777 88 53 +81 52 777 88 79 Fax: +81 52 777 89 01</p>	<p>Japan</p> <p>Bosch Rexroth Automation Corp. Electric Drives & Controls 1F, I.R. Building Nakamachidai 4-26-44, Tsuzuki-ku YOKOHAMA 224-0041, Japan</p> <p>Tel.: +81 45 942 72 10 Fax: +81 45 942 03 41</p>	<p>Korea</p> <p>Bosch Rexroth-Korea Ltd. Electric Drives and Controls Bongwoo Bldg. 7FL, 31-7, 1Ga Jangchoong-dong, Jung-gu Seoul, 100-391</p> <p>Tel.: +82 234 061 813 Fax: +82 222 641 295</p>
<p>Korea</p> <p>Bosch Rexroth-Korea Ltd. 1515-14 Dadae-Dong, Saha-Ku Electric Drives & Controls Pusan Metropolitan City, 604-050</p> <p>Tel.: +82 51 26 00 741 Fax: +82 51 26 00 747 gyhan@rexrothkorea.co.kr</p>	<p>Malaysia</p> <p>Bosch Rexroth Sdn.Bhd. 11, Jalan U8/82, Seksyen U8 40150 Shah Alam Selangor, Malaysia</p> <p>Tel.: +60 3 78 44 80 00 Fax: +60 3 78 45 48 00 hockhwa@hotmail.com rexroth1@tm.net.my</p>	<p>Singapore - Singapur</p> <p>Bosch Rexroth Pte Ltd 15D Tuas Road Singapore 638520</p> <p>Tel.: +65 68 61 87 33 Fax: +65 68 61 18 25 sanjay.nemade@boschrexroth.com.sg</p>	<p>South Africa - Südafrika</p> <p>TECTRA Automation (Pty) Ltd. 71 Watt Street, Meadowdale Edenvale 1609</p> <p>Tel.: +27 11 971 94 00 Fax: +27 11 971 94 40 Hotline: +27 82 903 29 23 georgv@tectra.co.za</p>
<p>Taiwan</p> <p>Bosch Rexroth Co., Ltd. Taichung Branch 1F., No. 29, Fu-Ann 5th Street, Xi-Tun Area, Taichung City Taiwan, R.O.C.</p> <p>Tel.: +886 - 4 -23580400 Fax: +886 - 4 -23580402 charlie.chen@boschrexroth.com.tw jim.lin@boschrexroth.com.tw david.lai@boschrexroth.com.tw</p>	<p>Thailand</p> <p>NC Advance Technology Co. Ltd. 59/76 Moo 9 Ramintra road 34 Tharang, Bangkhen, Bangkok 10230</p> <p>Tel.: +66 2 943 70 62 +66 2 943 71 21 Fax: +66 2 509 23 62 sonkawin@hotmail.com</p>		

Nordamerika – North America

USA Headquarters - Hauptniederlassung Bosch Rexroth Corporation Electric Drives & Controls 5150 Prairie Stone Parkway Hoffman Estates, IL 60192-3707 Tel.: +1 847 6 45 36 00 Fax: +1 847 6 45 62 01 servicebrc@boschrexroth-us.com repairbrc@boschrexroth-us.com	USA Central Region - Mitte Bosch Rexroth Corporation Electric Drives & Controls Central Region Technical Center 1701 Harmon Road Auburn Hills, MI 48326 Tel.: +1 248 3 93 33 30 Fax: +1 248 3 93 29 06	USA Southeast Region - Südwest Bosch Rexroth Corporation Electric Drives & Controls Southeastern Technical Center 3625 Swiftwater Park Drive Suwanee, Georgia 30124 Tel.: +1 770 9 32 32 00 Fax: +1 770 9 32 19 03	USA SERVICE-HOTLINE - 7 days x 24hrs - +1-800-REX-ROTH +1-800-739-7684
USA East Region – Ost Bosch Rexroth Corporation Electric Drives & Controls Charlotte Regional Sales Office 14001 South Lakes Drive Charlotte, North Carolina 28273 Tel.: +1 704 5 83 97 62 +1 704 5 83 14 86	USA Northeast Region – Nordost Bosch Rexroth Corporation Electric Drives & Controls Northeastern Technical Center 99 Rainbow Road East Granby, Connecticut 06026 Tel.: +1 860 8 44 83 77 Fax: +1 860 8 44 85 95	USA West Region – West Bosch Rexroth Corporation 7901 Stoneridge Drive, Suite 220 Pleasant Hill, California 94588 Tel.: +1 925 227 10 84 Fax: +1 925 227 10 81	
Canada East - Kanada Ost Bosch Rexroth Canada Corporation Burlington Division 3426 Mainway Drive Burlington, Ontario Canada L7M 1A8 Tel.: +1 905 335 55 11 Fax: +1 905 335-41 84 michael.moro@boschrexroth.ca	Canada West - Kanada West Bosch Rexroth Canada Corporation 5345 Goring St. Burnaby, British Columbia Canada V7J 1R1 Tel.: +1 604 205-5777 Fax: +1 604 205-6944 david.gunby@boschrexroth.ca	Mexico Bosch Rexroth Mexico S.A. de C.V. Calle Neptuno 72 Unidad Ind. Vallejo 07700 Mexico, D.F. Tel.: +52 5 754 17 11 +52 5 754 36 84 +52 5 754 12 60 Fax: +52 5 754 50 73 +52 5 752 59 43 mariofelipe.hernandez@boschrexroth.com.mx	Mexico Bosch Rexroth S.A. de C.V. Calle Argentina No 3913 Fracc. las Torres 64930 Monterrey, N.L. Tel.: +52 8 333 88 34...36 +52 8 349 80 91...93 Fax: +52 8 346 78 71 mario.quiroga@boschrexroth.com.mx

Südamerika – South America

Argentina - Argentinien Bosch Rexroth S.A.I.C. "The Drive & Control Company" Acassusso 48 41/47 1605 Munro Provincia de Buenos Aires Tel.: +54 11 4756 01 40 Fax: +54 11 4756 01 36 victor.jabif@boschrexroth.com.ar	Argentina - Argentinien NAKASE Servicio Tecnico CNC Calle 49, No. 5764/66 B1653AOX Villa Balester Provincia de Buenos Aires Tel.: +54 11 4768 36 43 Fax: +54 11 4768 24 13 nakase@usa.net nakase@nakase.com gerencia@nakase.com (Service)	Brazil - Brasilien Bosch Rexroth Ltda. Av. Tégula, 888 Ponte Alta, Atibaia SP CEP 12942-440 Tel.: +55 11 4414 56 92 +55 11 4414 56 84 Fax sales: +55 11 4414 57 07 Fax serv.: +55 11 4414 56 86 alexandre.wittwer@rexroth.com.br	Brazil - Brasilien Bosch Rexroth Ltda. R. Dr.Humberto Pinheiro Vieira, 100 Distrito Industrial [Caixa Postal 1273] 89220-390 Joinville - SC Tel./Fax: +55 47 473 58 33 Mobil: +55 47 9974 6645 prochnow@zaz.com.br
Columbia - Kolumbien Refflutec de Colombia Ltda. Calle 37 No. 22-31 Santafé de Bogotá, D.C. Colombia Tel.: +57 1 368 82 67 +57 1 368 02 59 Fax: +57 1 268 97 37 reflutec@neutel.com.co reflutec@007mundo.com			

Bosch Rexroth AG
Electric Drives and Controls
Bgm.-Dr.-Nebel-Str. 2
97816 Lohr a. Main, Germany
info@boschrexroth.de
www.boschrexroth.de



298518